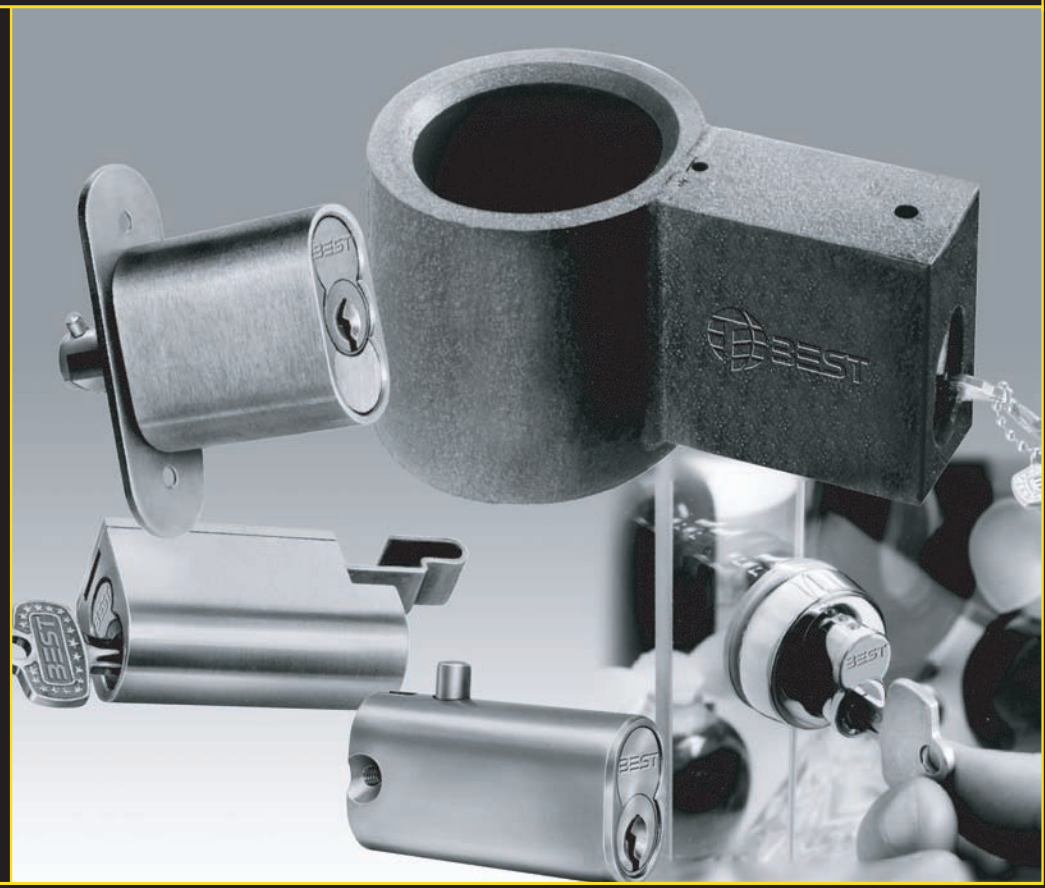


**STANLEY**<sup>®</sup>

Security Solutions

MISCELLANEOUS

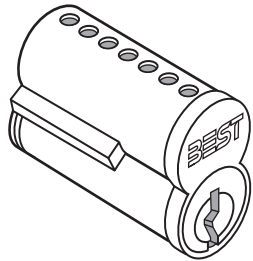


# MISCELLANEOUS

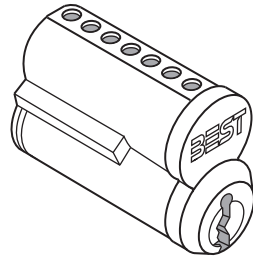


TABLE OF CONTENTS		Page	Page
C Series – Cores .....	2	2S Series – Sliding Door Lock .....	4
Patented Keying .....	2	3S Series – Sliding Panel Lock.....	5
2J Series – Semi-Trailer King Pin .....	3	4S Series – Sliding Door Cylinder .....	5
2P Series – Push Lock .....	4	KRD Series – Key Retaining Devices .....	6, 7

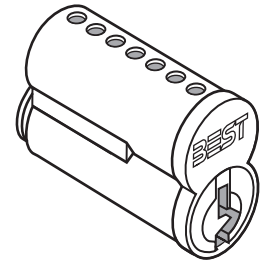
**C SERIES – CORES**



**1C core**  
(standard)

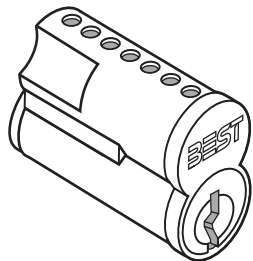


**1CK core**  
(patented)

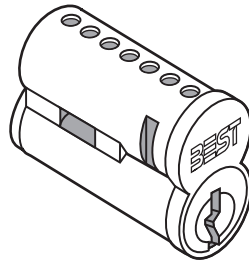


**1CP core**  
(premium)

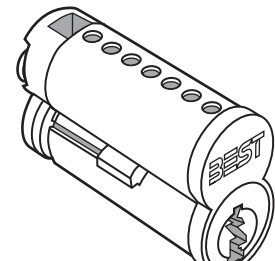
**SPECIAL APPLICATION CORES**



**3C core**  
(8E European lock)



**5C core**  
(High security  
mortise lock)



**6C core**  
(4S display case lock)

**HOW TO ORDER: C SERIES**

1C	7	A	1	Options	606
Core Type	Core Size	Keyway Code	Combination Code		Finish
1C– standard	5– 5 pin (1C only)	Designate specific keyway (A, E, etc.)	1– uncombined	B*– pick & drill resistant (1C only) K*– key trap T*– deadlocking (6C only)	605 606
1CK– patented	6– 6 pin (1C, 1CK only)		2– uncombined		612 613
1CP– premium	7– 7 pin				625 626
3C– for 8E cylinder					
5C**– high security					
6C– for 4S cylinder					

\*Extra cost option.

\*\*Long blade key required. If combined, you must specify keymark and number of keys.

**PATENTED KEYING**



**BEST Peaks®**  
Patented Keying

**BEST Peaks®**– For advanced solutions in key control and security, BEST offers Peaks®, the most adaptable and cost effective patented keying system on the market. The patented mechanism ensures that cylinders and cores will only operate with the Peaks® keys, which are only available through authorized BEST distributors.

For BEST products, Peaks® offers the security and convenience of a patented solution for interchangeable core. Peaks® is also available to adapt to a wide variety of locks from other manufacturers. All cylinders can be keyed into the same system, providing you the ability to operate all the locks at your facility using a single key, regardless of the lock manufacturer.



**J SERIES  
SEMI-TRAILER KINGPIN LOCK**



**2J7L11**  
Single latch armored kingpin lock operated by single key.



**2J7L21**  
Double latch armored kingpin lock requires two separate authorized keys to open.

**Operation**

The semi-trailer lock, locks onto the kingpin on a dropped semi-trailer to prevent hookup. The lock is automatically secured when pushed onto the kingpin and the key(s) can be withdrawn only in the locked position. Bright red finish signals driver not to back into lock. The deadlocking bolt functions listed below (D11, D21) feature a deadlocking bolt controlled by key to prevent bolt(s) from being shimmed or jimmed. A key is necessary both to secure and remove deadlocking bolt models.

**Specifications**

**Case**– Structural steel, machined solid steel head(s) heliarc welded to center body. Single head 8" x 8 3/4" x 4", weight approx. 15 lbs. Double head 11 1/2" x 3 3/4" x 4". Weight approx. 19 lbs.

**Latch projection**– 15/32"

**Cylinder(s)**– Brass with interchangeable core

**Finish**– Case, bright red crinkle finish; cylinders and cores 606

**Armored front protection**– Standard. Cylinder and core protected with hardened steel plate. Requires long blade key. Optional extended block (without armor package) to protect cylinder.

**Warning Flag Assembly**

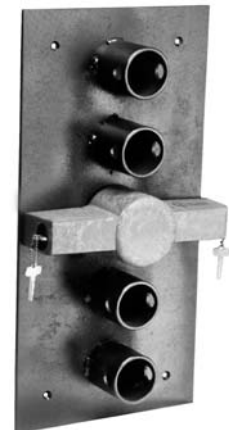
Includes eyebolt, snap, chains and danger flag. Hole in housing predrilled for attachment. Specify **2JOF1**



**2JOF1**

**Semi-Trailer Kingpin Storage Rack**

Mounts on wall. Holds 3 or 5 kingpin locks. Requires key to remove locks. Black finish standard. Plated corrosion-resistant finish available. Three-post mount **2JOR3 (2JOR3C-plated)**. Five-post mount **2JOR5 (2JOR5C-plated)**. Specify finish with order.



**Semi-Trailer Kingpin Storage Rack**

**HOW TO ORDER: J SERIES**

2J Series	7 Core Housing	L11 Function Code	Options
2J– standard body	7– 7-pin housing accepts all Best cores	L11– single latch type L21– double latch type D11– single deadlatch type D21– double deadlatch type	TA– extended block without armor

Must specify key mark and number of keys or designate L/C for less core.

**2P SERIES  
PUSH LOCKS FOR FILING CABINETS**

**Specifications**

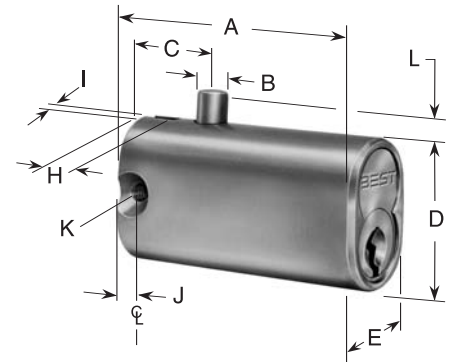
**Material**– Parts are solid brass; phosphor bronze springs.

**Dimensions**– See illustration and table.

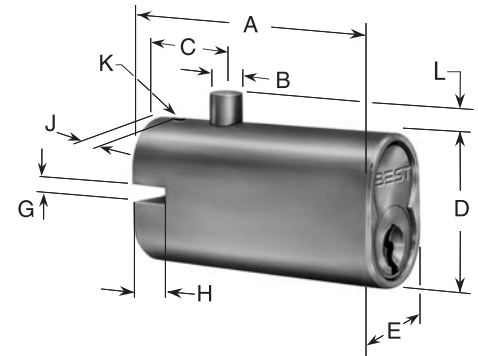
**Finish**– 2P series 626 (satin chrome) standard finish.

The 2P series incorporates the BEST interchangeable core and requires special cabinet preparation. It may be keyed individually, keyed alike, masterkeyed or grand-masterkeyed with other BEST removable core products.

Dimensions in inches												
Vertical Mounting Slot												
	A	B	C	D	E	F	G	H	I	J	K	L
<b>2P73 (7Barrel)</b>	2 9/32"	1/4"	19/32"	1 1/8"	3/4"			5/16"	1/8"	5/32"	#6-32	5/32"
Horizontal Mounting Slot												
<b>2P74 (7Barrel)</b>	2 9/32"	1/4"	19/32"	1 1/8"	3/4"	5/16"	1/8"			5/32"	#6-32	5/32"



**2P73 Vertical Mounting Slot**



**2P74 Horizontal Mounting Slot**

**HOW TO ORDER: 2P SERIES**

2P Series	7 Lock Housing	E Keyway	1 Combination Code	A Bolt Type	626 Finish
2P– file cabinet	7– 7-pin body may be keyed 6-pin	Designate specific keyway	1– uncombined 2– combined	A– rectangular B– rectangular with bevel C– round D– round for fire cabinet	626

Must specify key mark and number of keys or designate L/C for less core.

**2S SERIES  
PUSH LOCK FOR SLIDING DOORS**

**Function Code Chart**

Function Code	Door Thickness	Bolt	Operation
2S73	to 1 5/8"	19/32" dia. 1/2" throw	When unlocked, case of lock moves out through door stile and may be used as handle for moving door. To lock 2S73 and 2S74 push case in through door. Spring locking action. To lock 2S75 operate key and push case "IN" through door to engage bolt retaining pin behind strike plate in opposite door.
2S73 x TBM	7/8" to 1 5/8"	19/32" dia. 1/2" throw	
2S74 x TBM	7/8" to 1 5/8"	19/32" dia. 3/4" throw	
2S75	3/4" to 1 5/8"	1/2" dia. x 7/16" Bolt engagement 1/8" locking pin	

\*Screws may be cut up to 5/8" shorter for doors to 7/8" door thickness.

**Specifications**

**Case**– Extruded brass

**Width**– 1 1/2"

**Thickness**– 23/32"

**Inside Face Plate**– 2 3/4" x 7/8"; hole spacing 1 7/8"

**Detachable Face Plate**– 1/16" x 1 1/8" x 2 3/4"; hole spacing 2 3/16"

**Finish**– Base finish, 626, supplied unless otherwise specified



**2S73  
Surface mounted**



**2S74 x TBM  
through bolt mounted**



**2S75 Surface mounted with retaining pin**

**HOW TO ORDER: 2S SERIES**

2S Series	7 Core Housing	5 Function Code	626 Standard Finish	Options	**
2S– sliding door push lock	7– 7-pin housing accepts all Best cores	see above	626– standard 605 606 622 625	SP– support plate*	

\*Cannot be used with through bolt mounted (TBM) option. Available in 626 only.

\*\*Must specify key mark and number of keys or designate L/C for less core.



**3S SERIES  
SLIDING PANEL LOCK**

**Operation**

A stainless steel strap mounts permanently on the inner sliding panel. When panels are closed, the tongue of the strike strap extends beyond the edge of the outer panel. To lock panels, slide lock housing as close to overlapping panel edge as possible and lock by turn of key. Key is removable in locked position only.

**3S-Strike Strap Chart**

Type	Length	Panel
3SS1	4 1/4"	1/4"
3SS2	6 1/4"	1/4"
3SS3	6 1/4"	5/16"
3SS4	6 1/4"	13/32"
3SS5	6 1/4"	3/4"



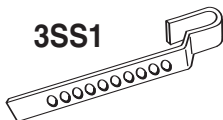
3S75



3S77

**Specifications**

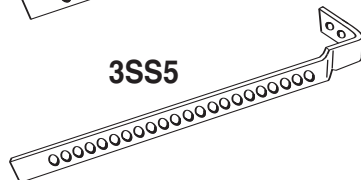
**Strike Strap**– Stainless steel, 1/2" wide  
**Lock housing**– Aluminum ANSI 156.11, Grade 1  
**Finish**– 627 aluminum only



3SS1



3SS2



3SS5

**HOW TO ORDER: 3S SERIES**

3S Series	7 Core Housing	5 Function Code	3SS2 Strike Strap	627 Standard Finish
3S– sliding panel lock	7– 7-pin housing accepts all Best cores housing 8– 1" extended housing	5– straight lock housing 7– captured panel lock	3SS2– standard unless otherwise specified	627

Must specify key mark and number of keys or designate L/C for less core.

**4S SERIES  
SLIDING DOOR CYLINDER**



4S73 Mounted on glass cabinet-unlocked position



4S73 Mounted on glass cabinet-locked position

**Specifications**

**Cylinder**– Head diameter– 1 3/8", cylinder projection– 3/8". Fits 1 3/16" diameter hole in door. Machined from solid brass.  
**Clamp Plate**– Stainless steel.  
**Mounting**– Cylinder attached with 2 stainless steel screws. Supplied with 2 clear vinyl washers for mounting on glass doors.  
**Door thickness**– 1/4"  
**Finish**– 625 bright chrome supplied standard. Available in 605, 606, 626.  
**Core**– Special 7 pin core prevents complete removal of core from cylinder. Machined from solid brass. 6C or 6CT core is required.  
**Operation**– Core body blocks door from sliding open when in the locked position. To unlock, insert key to retract locking lug and pull core forward to the unlocked position. 6C core must be ordered if key is to be removable in the locked or unlocked position. 6CT core must be ordered if key is to be removable only in the locked position.

**Operation**

The 4S73 locking cylinder for sliding doors offers quality security and Masterkey versatility by integrating a modified Best interchangeable core into the actual locking mechanism. This machined solid brass cylinder is designed for use on display cabinets, window displays, or other storage areas that are closed by sliding panels of glass, plastic, wood, etc. Available in a variety of finishes (bright chrome standard), the 4S73 can be keyed into any new or existing Best Access Masterkey System.

**HOW TO ORDER: 4S SERIES**

4S Series	7 Core Housing	3 Function Code	625 Standard Finish
4S– sliding door cylinder	7– 7 pin housing accepts (6C or 6CT only)	3– standard 4– for wood doors	625– standard 605 606 626






Must specify key mark and number of keys or designate L/C for less core.

## KRD SERIES KEY RETAINING DEVICES

### Key Retainer Device Operation and Benefits

The key retaining device is an effective tool for improving key control. With a key retaining device, a release key is inserted into the retaining device and rotated. The rotation of this key both releases the retained key and traps the release key. The release key remains trapped until the retained key is returned and rotated. When this happens, the release key can be extracted, but the retained key is trapped. These retaining devices establish accountability for important keys (ex: master keys, emergency bypass keys, etc.) and dramatically reduce both human mistakes and risk exposure for higher level keys. These effective put-and-take systems act as mechanical sign-out sheets. When the cores are installed, the standard #10 front mounting screws are concealed. Additional 1/4-20 threaded mounting holes are provided in the back of each KRD case.

### How It Functions...A simple put-and-take method of operation

				
GM or any high level key retained in KRD waiting for any authorized user to remove it when needed	An authorized user inserting their personally identified release key	User rotates release key and the high level retained key is now ready for removal	Authorized user removing the previously secured high level key and can use it as needed	Authorized user key is retained (held captive/trapped) until the high level key is returned to its secure location

### KRD-2 BEST Core Model (Cores and Keys not included)

Two core retaining device with one retained core and key and one release core and key. Accepts 5, 6 and 7 pin BEST cores.

**Case:** Precision machined from solid aircraft aluminum bar stock

**Size:** 2 1/4" High x 4 1/2" Long x 2 1/4" Deep.

**Weight:** 2 pounds

**Finish:** Clear anodized – 628 \*

**Options:** – S: Internal low-voltage SPDT switch

– SS: Security Seal

\* Other colors are available



**KRD-2**

### KRD-2H Hybrid (Cores and Keys not included)

The Hybrid KRD is used to combine, in one device, a BEST core with another manufacturer's core. Two models are currently available: Sargent RC and Schlage FSIC (contact your local BEST office for information on other models).



**KRD-2H – SAR/BEST**



**KRD-2H – BEST/SCH**

These two KRD-2H Hybrids have the BEST core as the retained position, but the user can decide which core position is to be the release and which is to be the retained.

Specifications for KRD-2H Hybrids are the same as the KRD-2 shown above.

**KRD-2 Non-BEST Full Size Core Models** (Cores and Keys not included)

Identical in operation to the KRD-2 for BEST cores, but these devices will accept other manufacturers' IC's and RC's. Some manufacturers of both 6 and 7-pin cores require a different version for each. A complete listing appears in HOW TO ORDER below. Specifications for these models are the same as the KRD-2 shown on the previous page.

**KRD-3 BEST Core Dual Function Model** (Cores and Keys not included)

This three core model accepts BEST 5, 6 and 7-pin cores and provides the user with a choice of two different functions:

**Function "A" – Dual Custody - 2 release keys presented to release 1 retained key:** Two release keys must be simultaneously inserted into the retaining device and rotated 90 degrees. The rotation of these two keys traps them and releases the retained key. The release keys remain trapped until the retained key is returned and rotated. When this happens, the release keys can be extracted, but the retained key is trapped.

**Function "B" – 1 release key presented to release 2 retained keys:** A release key is inserted into the retaining device and rotated 90 degrees. The rotation of this key releases the retained keys, which should both be simultaneously removed, and traps the release key. The release key remains trapped until both of the retained keys are returned and rotated. When this happens, the release key can be extracted, but the retained keys are trapped.

**Case:** Precision machined from solid aircraft aluminum bar stock

**Size:** 2 1/4" High x 6 3/4" Long x 2 1/4" Deep.

**Weight:** 3 pounds

**Finish:** Clear anodized – 628 \*

**Options:** – **S:** Internal low-voltage SPDT switch  
 – **SS:** Security Seal(s)  
 Specify quantity and post location(s)  
 \* Other colors are available



**KRD-3 (Function "A" Shown)**

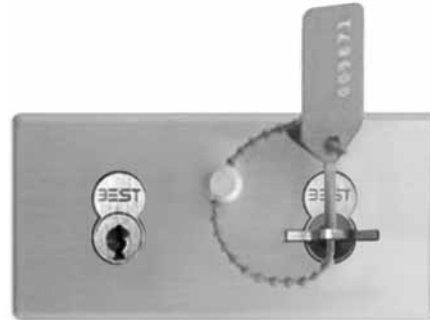
**KRD Options**

**-S Switch**

Internal low-voltage SPDT switch rated at 5A, 125VAC supplied with a 3-wire, 36" jacketed cable. This switch can be used to connect any KRD to an annunciator, control circuitry, a camera, an access control system with alarm monitoring capability, a linked output, etc.

**-SS Security Seal(s)** (Seals not included)

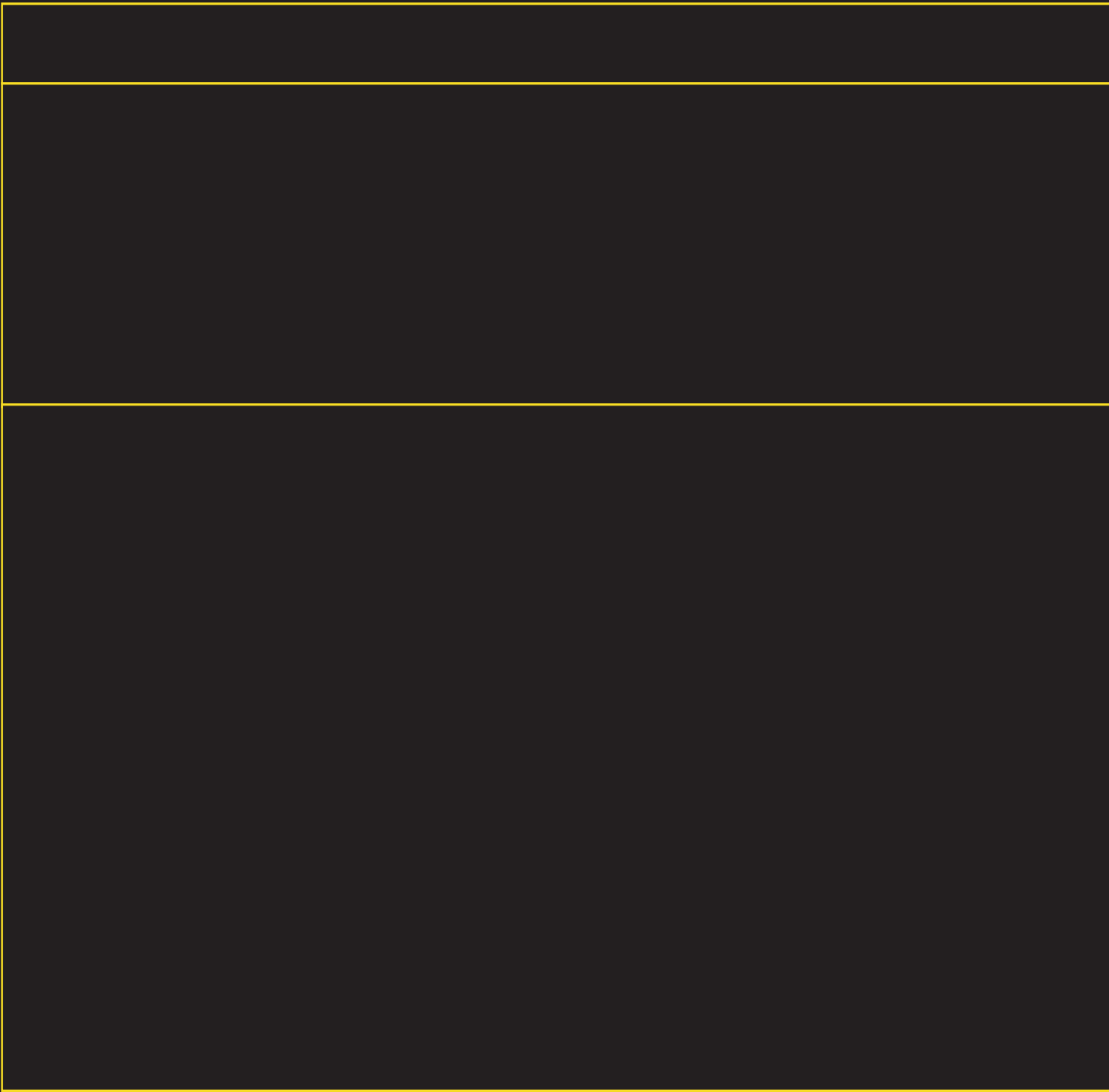
Allows you to use a breakable seal on a retained key to provide a simple and effective visual indicator that this key has NOT been used.



**-SS Option (Shown on KRD-2)**

**HOW TO ORDER: KEY RETAINING DEVICES**

Key Retaining Devices	Part Number
KRD-2 BEST Core Model	UL-KRD-2
KRD-2H Hybrid (Sargent/BEST Model)	UL-KRD-2H SAR/BEST
KRD-2H Hybrid (BEST/Schlage FSIC Model)	UL-KRD-2H BEST/SCH
KRD-3 BEST Core Dual Function Model	UL-KRD-3
<b>Non-BEST Full Size Core Models</b>	
KRD-2 Corbin Russwin 6-pin IC	UL-CR6-KRD-2
KRD-2 Corbin Russwin 7-pin IC	UL-CR7-KRD-2
KRD-2 Medeco IC	UL-MED-KRD-2
KRD-2 Sargent RC	UL-SAR-KRD-2
KRD-2 Schlage FSIC	UL-SCH-KRD-2
KRD-2 Yale 6-pin IC	UL-YA6-KRD-2
KRD-2 Yale 7-pin IC	UL-YA7-KRD-2
Switch and Security Seal Options	Add -S and/or -SS suffix
Also available: Special KRD-4, Custom Hybrids and Functions, Multi-Key Switches, etc.	



For more information on BEST's full line of security solutions visit our web site at [www.stanleysecuritysolutions.com](http://www.stanleysecuritysolutions.com) or call 1-317-849-2250 for the name of the Stanley Security Solutions office nearest you.

Product information contained in this catalog has been compiled and presented with as much care and completeness as is reasonably possible. Errors or mistakes may be present, and in many cases, reliance has been placed on information supplied by other manufacturers which may be in error or which may be subject to changes or modifications by the manufacturer without notice and without obligation. Therefore, no guarantee can be made or should be assumed or implied with regards to product information contained in this catalog.

**Product Warranty** – Best Access Systems warrants that all of its products sold under its trade name "BEST" are free of defects in materials, workmanship and operation, normal wear and tear excepted, for a period of **three years** from the date of sale to the original purchaser.

**Concerning Proper Installation:** Installation instructions for any Best Access Systems product should be carefully followed for proper operation of the installed product. If improperly installed, malfunction of the product may result.



Security Solutions

Stanley Security Solutions, Inc.

6161 E. 75th Street Indianapolis, Indiana 46250

[www.stanleysecuritysolutions.com](http://www.stanleysecuritysolutions.com)