

KEY COMBINATOR

SERVICE MANUAL



CREDITS/COPYRIGHT

©2001 Best Lock Corporation dba Best Access Systems. All rights reserved. Printed in the United States of America.

Information in this document is subject to change without notice and does not represent a commitment on the part of Best Access Systems. The software described in this document are furnished under a license agreement or nondisclosure agreement.

This publication is intended to be an accurate description and set of instructions pertaining to its subject matter. However, as with any publication of this complexity, errors or omissions are possible. Please call your BEST distributor or Best Access Systems at (317) 849-2250 if you see any errors or have any questions. No part of this manual and/or databases may be reproduced or transmitted in any form or by any means, electronic or mechanical, including photocopying, recording, or information storage and retrieval systems, for any purpose, without the express written permission of Best Access Systems.

This document is distributed as is, without warranty of any kind, either express or implied, respecting the contents of this book, including but not limited to implied warranties for the publication's quality, performance, merchantability, or fitness for any particular purpose. Neither Best Access Systems, nor its dealers or distributors shall be liable to the user or any other person or entity with respect to any liability, loss, or damage caused or alleged to be caused directly or indirectly by this publication.

The Life Safety Code is a registered trademark of the National Fire Protection Association.

Written and designed by Best Access Systems and Avalon Group, Inc., Indianapolis, Indiana.

T61804 Rev - 1837172 ER7991-6 October 2001

CONTENTS

FIGURES v

GETTING STARTED 1-1

- Introduction 1-1
- Product family diagram 1-2
- Documentation package 1-3
- Technical support 1-3
 - Support services 1-3
 - Telephone and web technical support 1-3
 - Training seminars 1-3

PARTS 2-1

- Exploded diagram of a key combinator—left hand 2-2
- Exploded diagram of a key combinator—right hand 2-3
- Key options 2-4
 - Standard key 2-4
 - Premium key 2-4
 - Patented key 2-4
- Keyway options 2-5

SERVICE AND MAINTENANCE 3-1

- Combinator handing 3-2
 - Left-handed vs. right-handed combinators 3-2
- Maintenance tools 3-2
 - BEST tools 3-2
 - Additional tools 3-3
- Cutting keys 3-4
 - Loading the key 3-4
 - Cutting the key 3-5
 - Unloading the key 3-6
- Converting the combinator between the A2, A3, and A4 systems 3-7
 - Replacing the depth selector 3-7
- Replacing parts 3-9
 - Replacing the punch and die 3-9
 - Replacing the key carriage 3-11
 - Replacing the operating lever 3-13
- Calibrating the key combinator 3-16
 - Cutting a calibration key 3-16
 - Placing the key in the gauge 3-18
 - Reading the gauge 3-18
 - Totaling the measurement 3-19
 - Checking the measurement 3-19
 - Adjusting the depth selector 3-20
- Adjusting the key clamp spring 3-25
- Preventative maintenance 3-27
- Cleaning parts 3-27
 - Cleaning the punch and die 3-27
 - Cleaning the key carriage 3-27
- Lubricating parts 3-28
 - Guidelines for lubrication 3-28
 - Lubricating the key combinator housing 3-28
- Troubleshooting 3-31

GLOSSARY A-1

PREVENTATIVE MAINTENANCE B-1

INDEX C-1

FIGURES

GETTING STARTED

Key combinator product family 1-2

PARTS

LH key combinator 2-2

RH key combinator 2-3

Standard key blank 2-4

Premium key blank 2-4

Patented key blank 2-4

SERVICE AND MAINTENANCE

BEST maintenance tools 3-2

Loading a key 3-4

Key in the key clamp spring 3-5

Cutting a key 3-6

Removing the depth selector 3-7

Reinstalling the depth selector 3-8

Punch and die assembly 3-9

Inserting the punch into the T-slot 3-10

Removing the key carriage 3-11

Reinstalling the key carriage 3-12

Depressing the key carriage plungers 3-13

Removing the operating lever 3-14

Reinstalling the operating lever 3-15

Cutting a calibration key 3-17

Inserting a key into the key gauge	3-18
Calibration measurement scale	3-19
Marking the depth selector assembly	3-20
Loosening the spanner nut	3-21
Turning the depth adjuster counterclockwise	3-22
Turning the depth adjuster clockwise	3-23
Loading a key	3-25
Adjusting the key clamp spring	3-26
Lubricating parts	3-29
Lubricating the punch and die	3-30

1

GETTING STARTED

INTRODUCTION

The *Key Combinator Service Manual* contains essential information to help you maintain your BEST key combinator.

PRODUCT FAMILY DIAGRAM

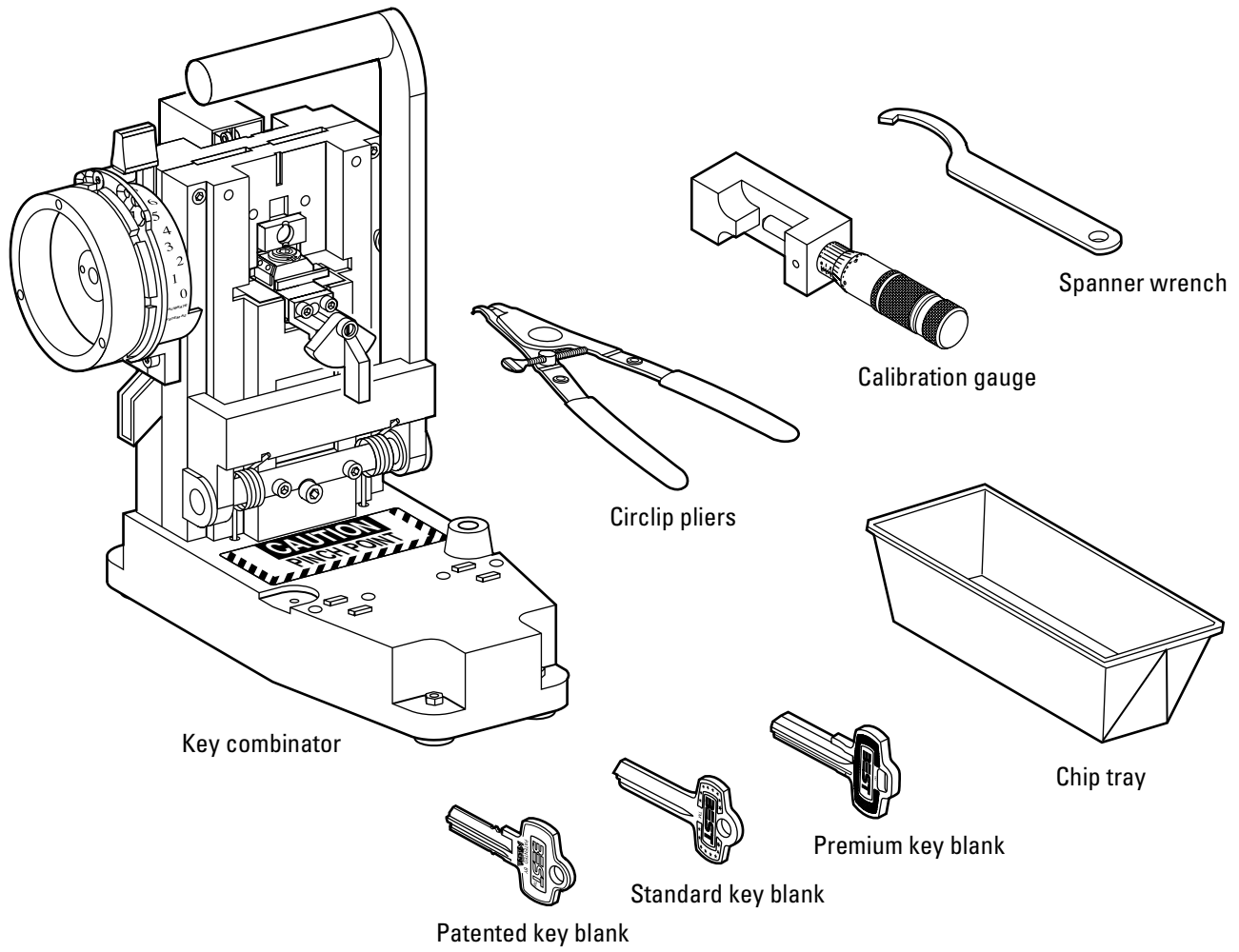

Figure 1.1 Key combinator product family

DOCUMENTATION PACKAGE

The following documentation is available to help you with the installation, operation, and maintenance of your BEST key combinator along with associated service equipment. These documents also can be ordered separately from the product.

Document Title	Doc. No.
<i>Core and Key Service Manual</i>	T35527
<i>Operating Instructions for AD432 Key Combinator</i>	T35531
<i>Operating Instructions for AD433 Key Combinator</i>	T35529
<i>Operating Instructions for AD502 Micrometer Key Gauge</i>	T35530

TECHNICAL SUPPORT

Support services When you have a problem with a BEST key combinator, your first resource for help is the *Key Combinator Service Manual*. If you cannot find a satisfactory answer, contact your local BEST Representative.

Telephone and web technical support A factory-trained Certified Product Specialist (CPS) is available in your area whenever you need help. Before you call, however, please make sure that the product is in your immediate vicinity, and that you are prepared to give the following information:

- what happened and what you were doing when the problem arose
- what you have done so far to correct the problem.

Best Access Systems Representatives provide telephone technical support for key combinators and related products. You may locate the representative nearest you by calling (317) 849-2250 Monday through Friday, between 7:00 a.m. and 4:00 p.m. eastern standard time; or visit the web page, www.BestAccess.com.

Training seminars Best Access Systems regularly holds factory training seminars for owners of BEST masterkey systems. Your BEST Representative may hold regular seminars as well. Contact your representative for information on these seminar opportunities.

2

PARTS

The following pages contain descriptions and figures for the key combinator.

EXPLODED DIAGRAM OF A KEY COMBINATOR—LEFT HAND

Item†	Part No.	Qty.	Description
1	A70595	1	Operating lever assembly
2	C70580	1	Premium key carriage
not shown	C70610	1	Key carriage for BEST/Peaks—7-pin
not shown	C70601	1	Key carriage for BEST/Peaks—6-pin
3	B70341	1	Punch and die assembly
not shown	B70625	1	Punch and die assembly for BEST/Peaks
4	A70325	1	Depth selector assembly—A2
not shown	A70326	1	Depth selector assembly—A3
not shown	A70327	1	Depth selector assembly—A4

† See page 3-7 for instructions on converting between the A2, A3, and A4 Systems.

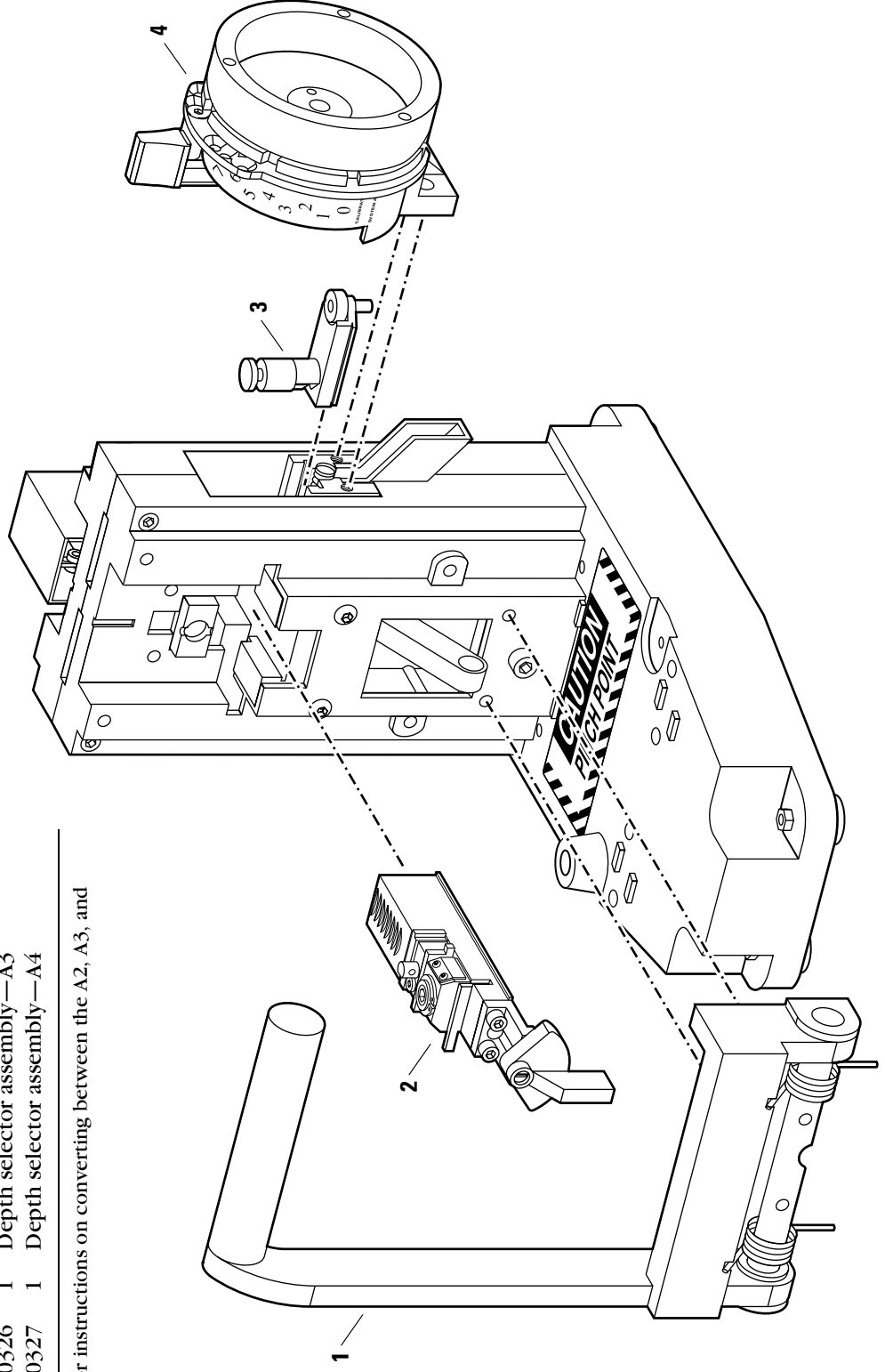

Figure 2.1 LH key combinator

EXPLODED DIAGRAM OF A KEY COMBINATOR—RIGHT HAND

Item†	Part No.	Qty.	Description
1	C70322	1	Depth selector assembly—A2
not shown	C70323	1	Depth selector assembly—A3
not shown	C70324	1	Depth selector assembly—A4
2	B70341	1	Punch and die assembly
3	C70578	1	Standard key carriage
not shown	C70579	1	Premium key carriage
4	A70591	1	Operating lever assembly

† See page 3-7 for instructions on converting between the A2, A3, and A4 Systems.

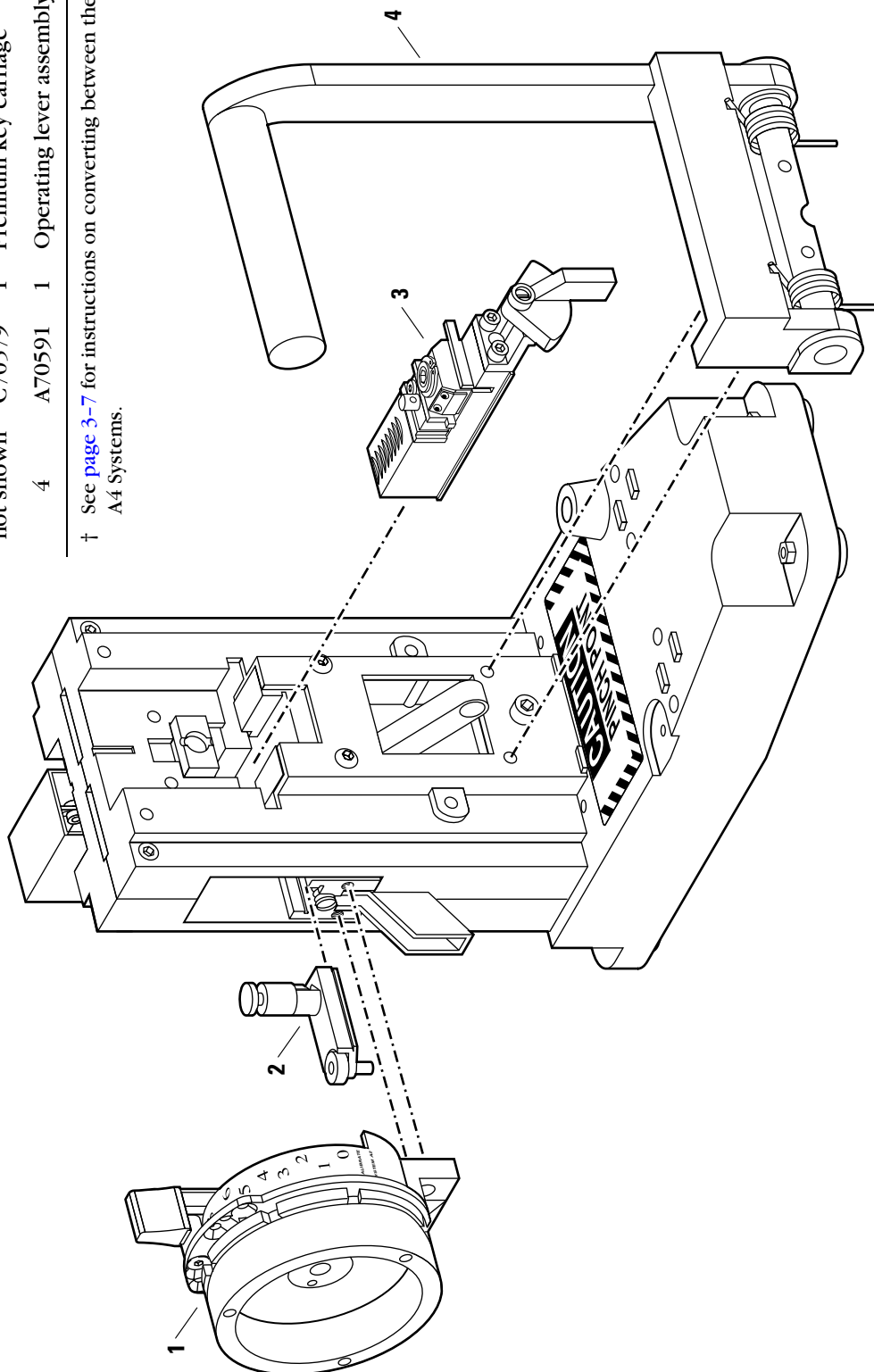

Figure 2.2 RH key combinator

KEY OPTIONS

The following key options are offered by BEST. Refer to the *Core and Key Service Manual (T35527)* for ordering information.

Standard key Standard keys are cut by the AD433 key combinator.

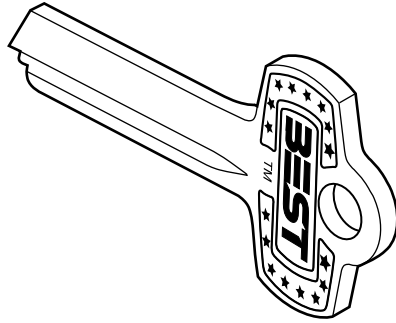

Figure 2.3 Standard key blank

Premium key Premium keys are cut by the AD433P key combinator.

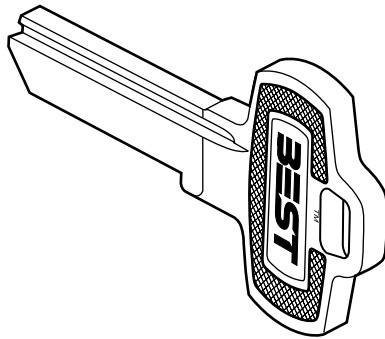

Figure 2.4 Premium key blank

Patented key PEAKS patented keys are cut by the AD437 and AD436 key combinator.

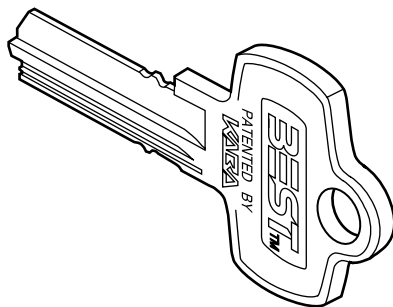

Figure 2.5 Patented key blank

KEYWAY OPTIONS

The following section lists BEST keyways and the combinators that must be used to cut the keys.

Note: BEST key combinators are available only to registered BEST customers who currently have the A2, A3, or A4 masterkey system. For more information, contact your local BEST Representative.

Standard keyways

All standard keyways require a RH configuration for the key combinator.

Premium keyways

Some premium keyways require a LH configuration for the key combinator and some require a RH configuration. See the table below.

Configuration	Keyway
RH	WA
	WB
	WC
	WG
	WH
	WK
	WY
LH	WD
	WE

Patented keyways

All patented keyways require a LH configuration. The B1 and B2 keyways are the only Peaks keyways available to use with the AD437 and AD436 key combinators.

3

SERVICE AND MAINTENANCE

This chapter contains instructions for servicing and maintaining key combinator components, and a section for troubleshooting common problems.

To	See page
Understand combinator handing	3-2
Look at maintenance tools	3-2
Cut keys	3-4
Convert your combinator between A2, A3, and A4 systems	3-7
Replace the punch and die	3-9
Replace the key carriage	3-11
Replace the operating lever	3-13
Calibrate the key combinator	3-16
Adjust the key clamp spring	3-25
Create a preventative maintenance plan	3-27
Clean the punch and die	3-27
Clean the key carriage	3-27
Lubricate parts	3-28
Troubleshoot common problems	3-31

COMBINATOR HANDING

Left-handed vs. right-handed combinators

The terms “left-handed” and “right-handed” describe the handing of a combinator, but this is not a convenience feature for left-handed or right-handed individuals. The handing on a combinator is distinguished by the position of its operating lever. The operating lever position determines which types of keys the combinator can cut.

Left-handed key combinator

When facing the combinator, the operating handle is attached to the left side of the left-handed or LH key combinator. A LH key combinator cuts patented or left-handed premium keys. It does not cut standard keys.

Right-handed key combinator

When facing the combinator, the operating handle is attached to the right side of the right-handed or RH key combinator. A RH key combinator cuts premium or right-handed standard keys. It does not cut patented keys.

To determine which keys are appropriate for your security needs, contact your BEST Representative. See [page 2-5](#) for more information on key combinators and their keyway types.

MAINTENANCE TOOLS

BEST tools

The following tools are provided by BEST for servicing your key combinator.

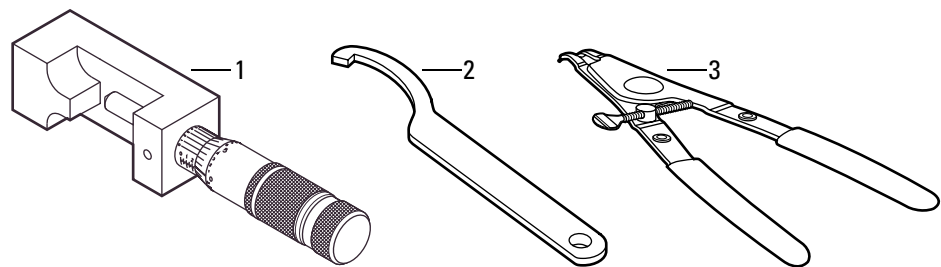

Figure 3.1 BEST maintenance tools

Maintenance tools parts list

Item	Nomenclature	Part No.	Qty.	Description
1	AD502	B70564	1	Key calibration gauge—standard
not shown	AD502D	B70574	1	Key calibration gauge—digital
2		A70558	1	Spanner wrench
3		HT03009	1	Circlip pliers

Additional tools The following Allen wrenches are used for servicing your key combinator:

- 3/32"
- 7/64"
- 1/8"
- 9/64"
- 5/32"
- 3/16".

CUTTING KEYS

BEST recommends that you secure your key combinator to a flat surface before you begin cutting keys. You can install bolts either through each of the rubber feet or through two holes on the base of the combinator. Contact BEST for further instructions.

Loading the key To load a BEST standard key blank:

1. Gripping the key clamp knob, pull the key carriage completely forward.
2. Turn the key clamp knob counterclockwise to open the key clamp spring (for left-handed combiners, turn the key clamp knob clockwise). See [Figure 3.2](#).

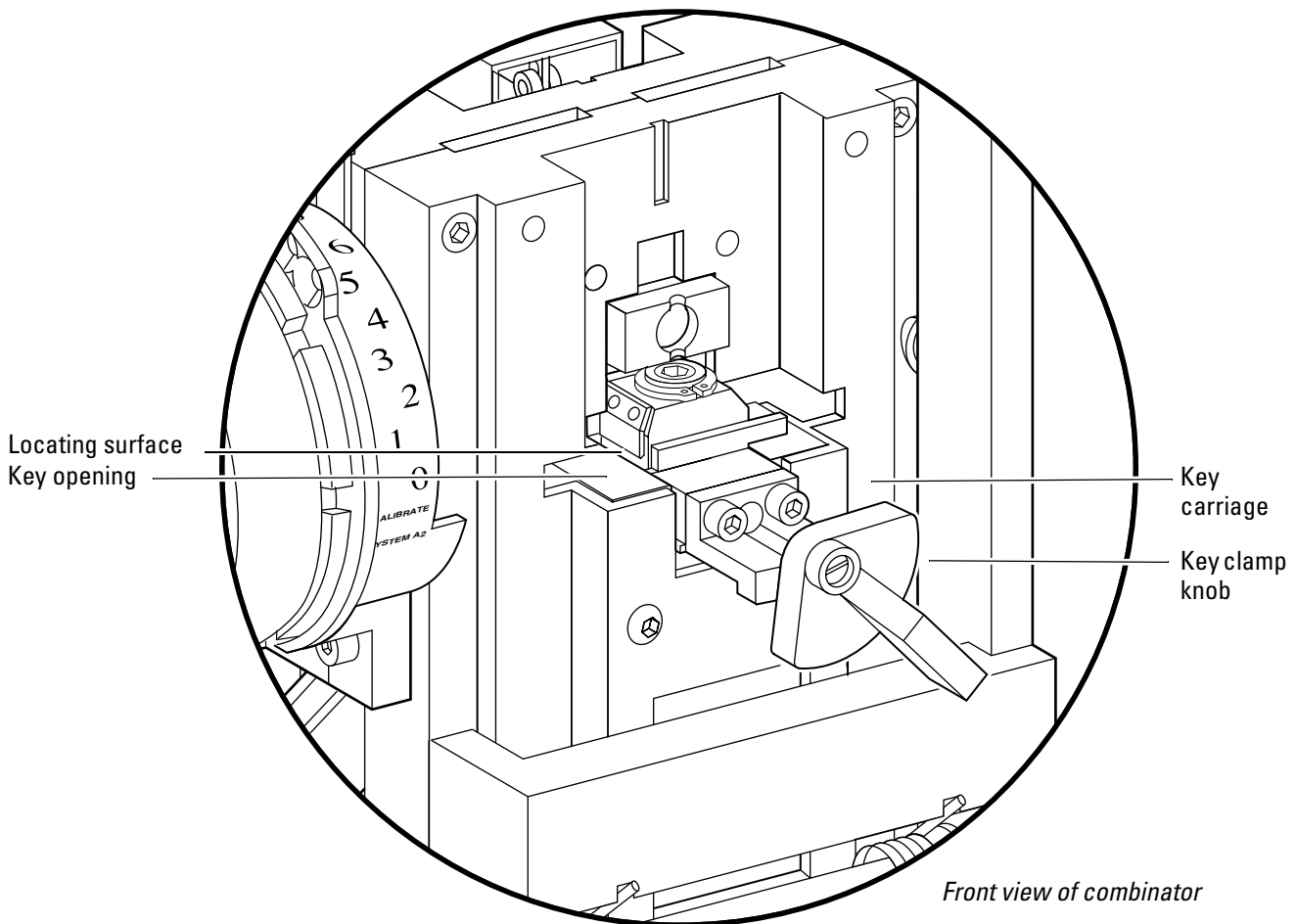

Figure 3.2 Loading a key

3. With the curved edge of the key blank against the locating surface, slide the key blank into the key opening. Make sure that the knife edge of the key clamp spring fits into the groove of the key. See [Figure 3.3](#).

4. Turn the key clamp knob clockwise, locking the key blank into the key carriage (for left-handed combinators, turn the key clamp knob counterclockwise).

The key clamp knob hangs loosely in the six o'clock position, as shown in [Figure 3.3](#)

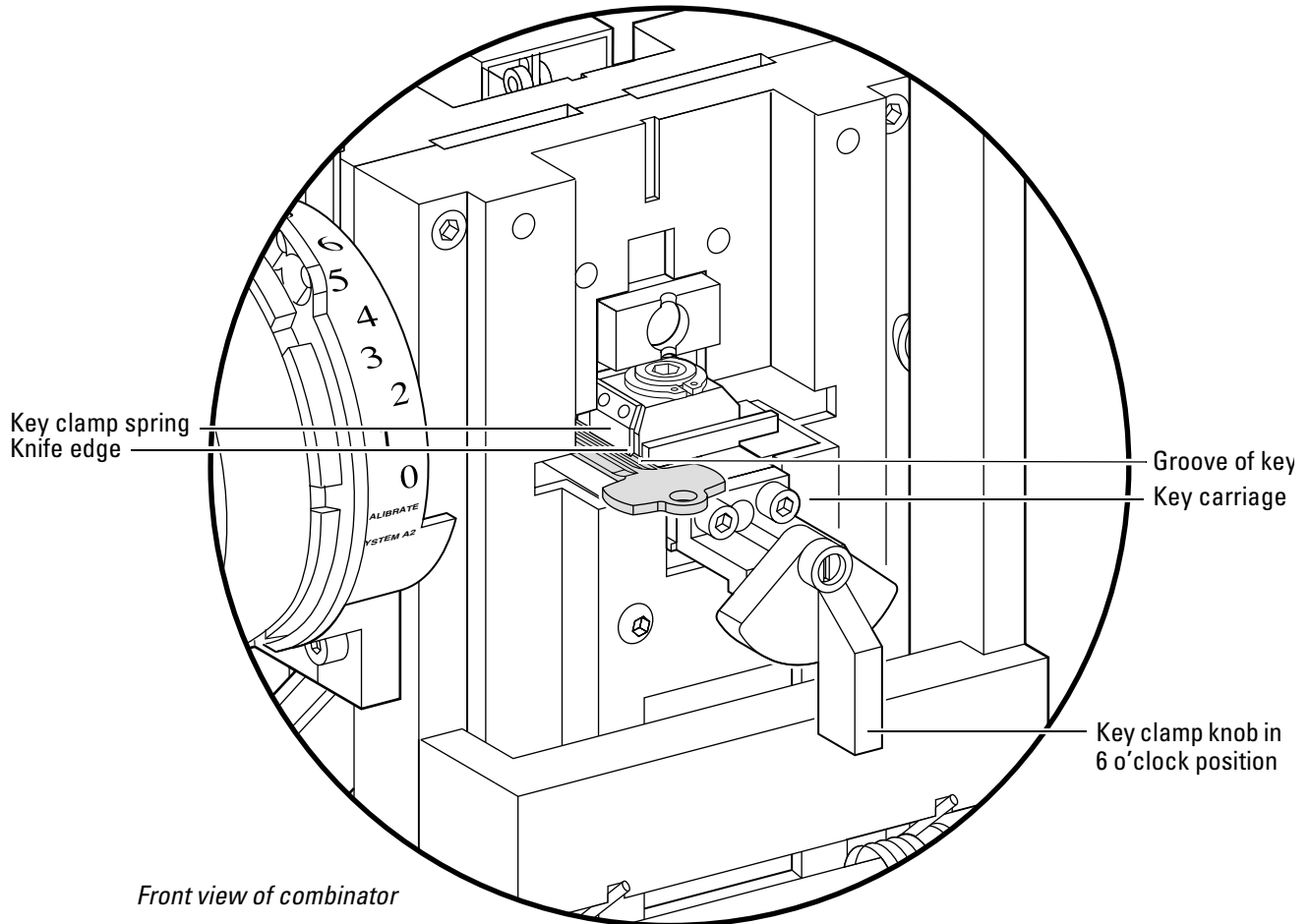

Figure 3.3 Key in the key clamp spring

Cutting the key To cut a BEST standard key blank:

1. Before you begin to cut keys, make sure that the key carriage is still completely forward.
2. Move the depth selector lever to the “0” mark for the setup stroke.
3. Pull the operating lever down firmly until it strikes the rubber bumper; then, let the operating lever move back up.

Failure to strike the rubber bumper may cause the key carriage to move to the next space too soon.



The combinator automatically moves the key carriage and key blank into place for the first keycut.



Do not touch the key carriage during key cutting. The combinator precisely advances the key carriage with each stroke of the operating lever.

4. Move the depth selector dial to the keycut depth number that you need for your key. See [Figure 3.4](#).



Be sure to let go of the depth selector before making a cut. Any pressure placed on the depth selector dial can cause the key to be cut incorrectly.

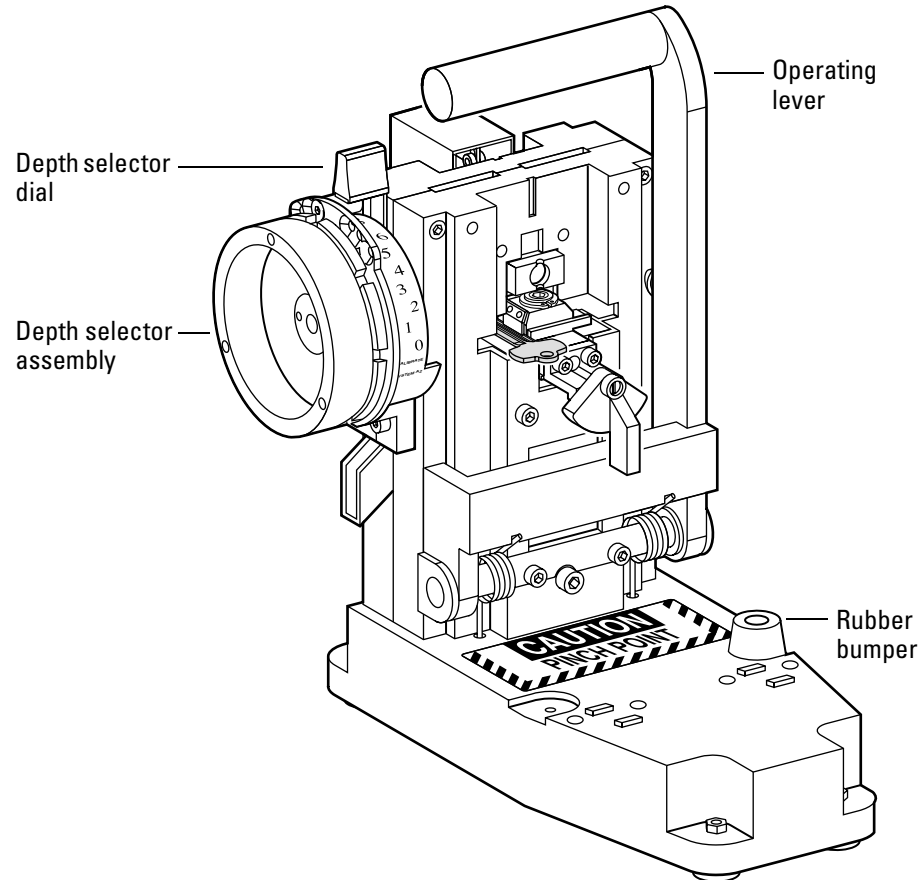

Figure 3.4 Cutting a key

5. Pull the operating lever down firmly until it strikes the rubber bumper; then, let the operating lever move back up.
The combinator makes the first cut and automatically moves the key carriage and key blank into place for the next cut.
6. Repeat Steps 3 and 4 until you have made all of the cuts on the key.

Unloading the key

To unload a BEST standard key:

1. Gripping the key clamp knob, pull the key carriage completely forward.
2. Turn the key clamp knob counterclockwise to open the key clamp spring (for left-handed combiners, turn the key clamp knob clockwise).
3. Slide the key out.

CONVERTING THE COMBINATOR BETWEEN THE A2, A3, AND A4 SYSTEMS

The BEST AD433 key combinator gives you the ability to change from one masterkey system to another by replacing the depth selector. For example, you may want to change from an A2 System to an A4 System.

Replacing the depth selector

To remove the depth selector:

1. Using a 5/32" Allen wrench, unscrew the two socket head machine screws that secure the depth selector to the side of the combinator. See [Figure 3.5](#).
2. Remove the depth selector. Save the screws.

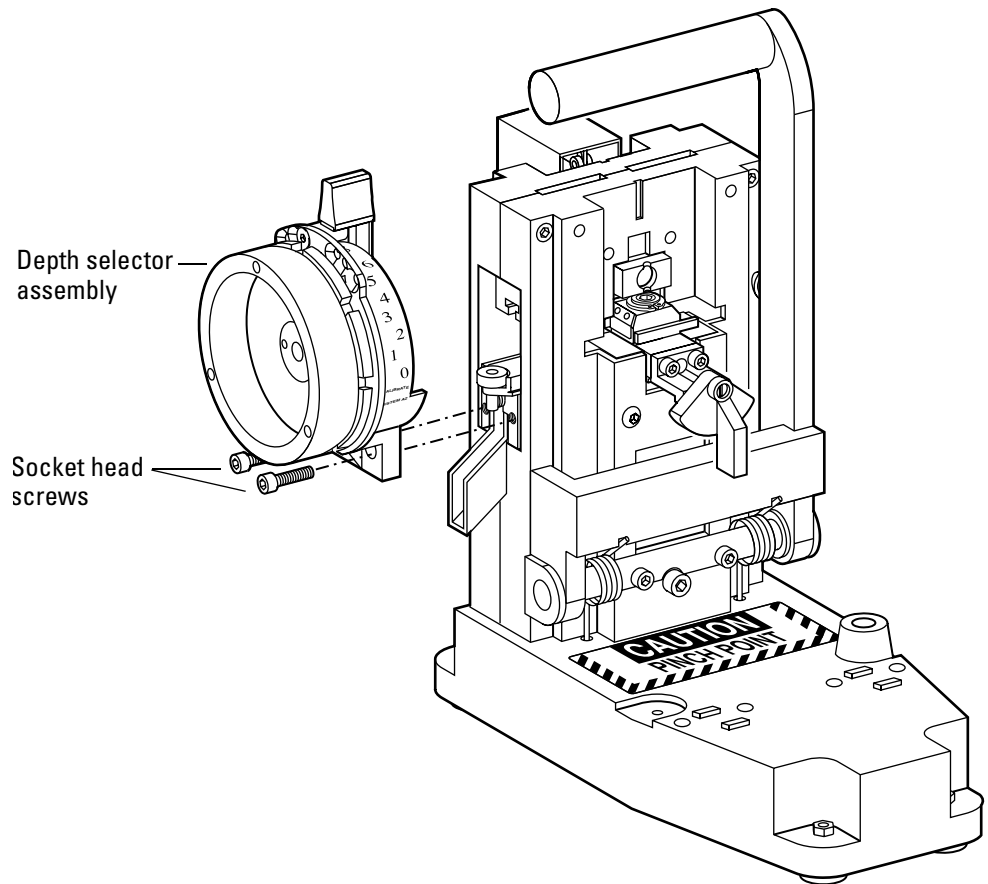

Figure 3.5 Removing the depth selector

To reinstall the depth selector:

1. Turn the dial on the depth selector assembly to the “0” mark.
2. Align the two holes on the bottom of the depth selector assembly with the threaded holes on the combinator. See [Figure 3.6](#).

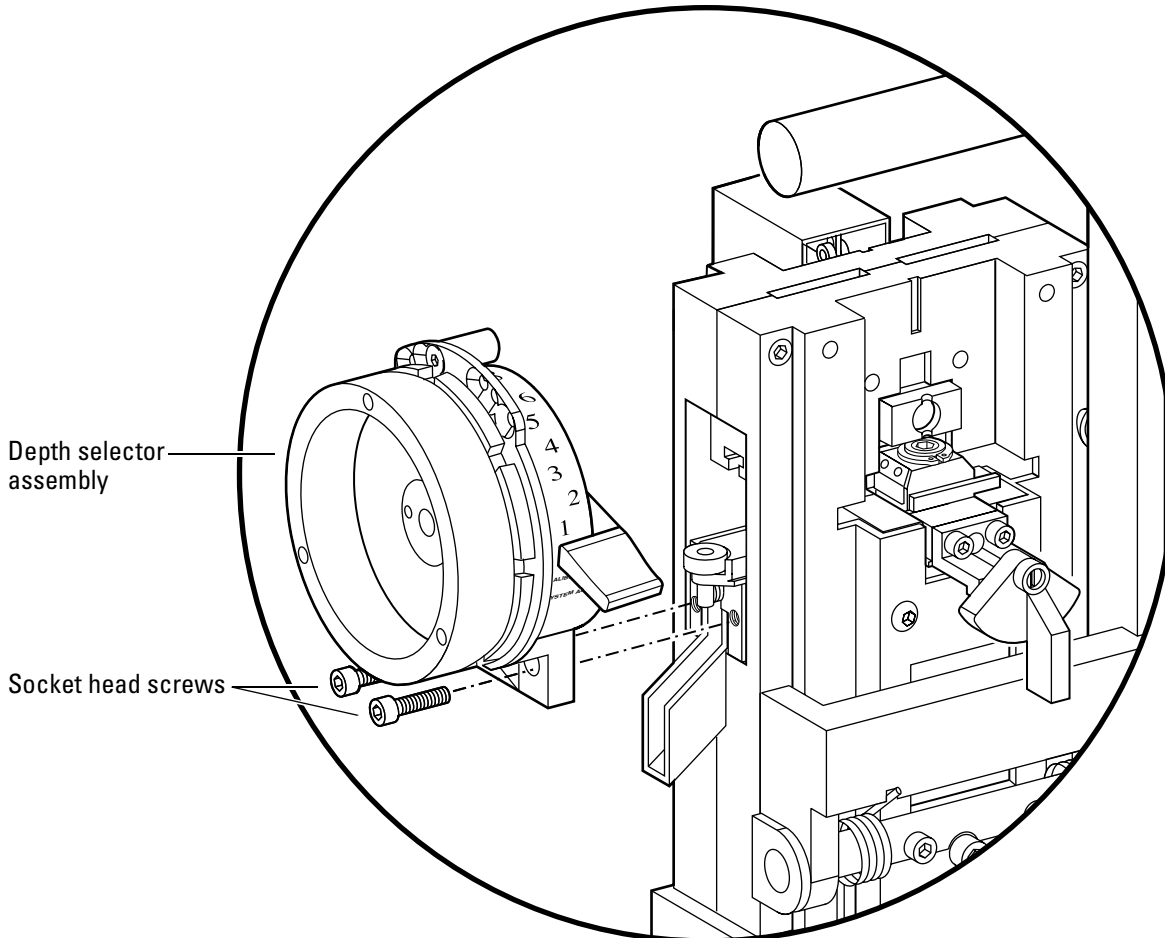

Figure 3.6 Reinstalling the depth selector

3. Insert two 5/32" socket head machine screws through the holes and tighten them with a 5/32" Allen wrench.
4. Calibrate a key to make sure the new depth selector assembly is properly installed ([page 3-16](#)).

REPLACING PARTS

Replacing the punch and die

To remove the punch and die:

1. Make sure that the operating lever is in the upright position.
2. Remove the depth selector ([page 3-7](#)). Save all of the parts.
3. Remove the punch and die assembly. See [Figure 3.7](#).

Note: The spring that sits below the punch and die assembly can pop out during removal.

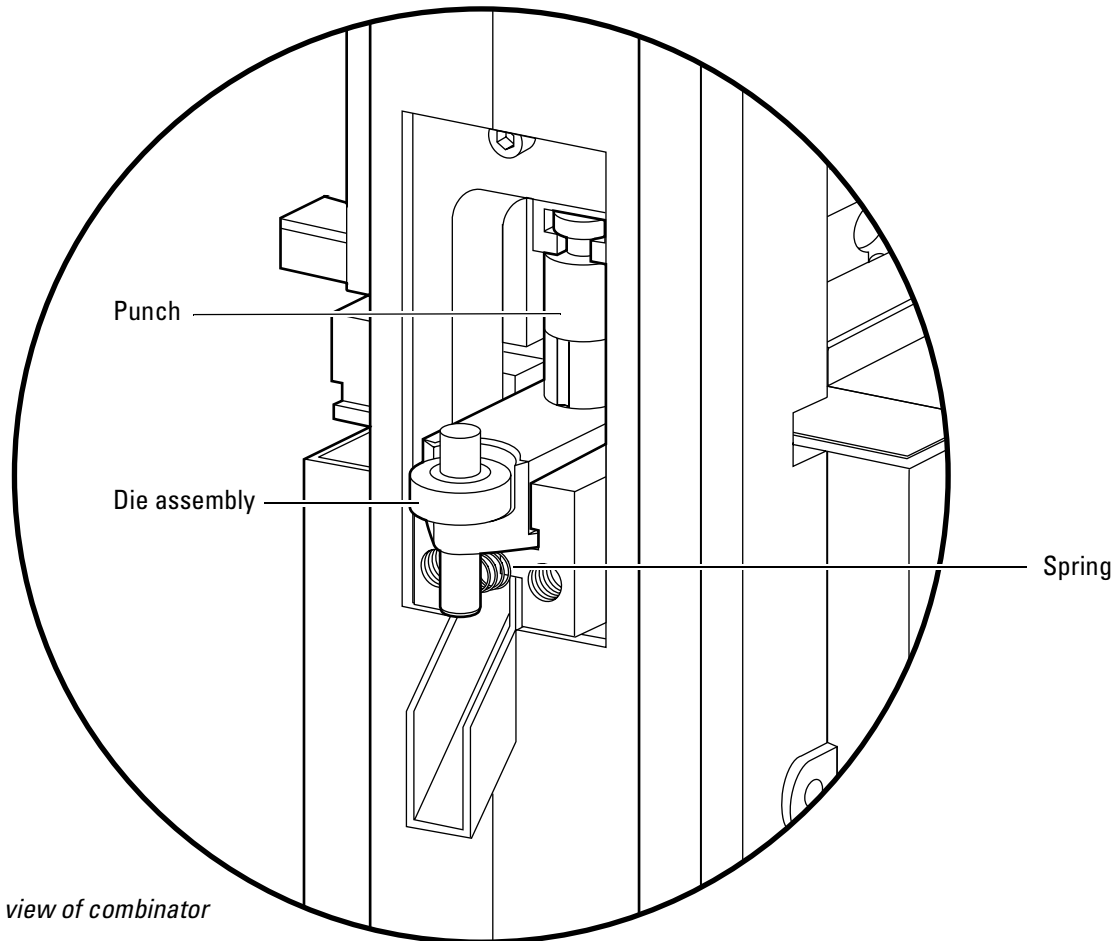

Side view of combinator

Figure 3.7 Punch and die assembly

To reinstall the punch and die:

1. Make sure that the spring is resting in the space between the guide rails.
2. Assemble the punch so that it sits in the die as shown in [Figure 3.8](#).
3. Lightly lubricate both sides of the die ([page 3-30](#)).
4. While making sure that the punch does not extend below the bottom of the die, insert the die into the slots of the guide rail.
5. Place the top of the punch into the T-slot of the punch guide rail. See [Figure 3.8](#).
6. Reinstall the depth selector ([page 3-8](#)).
7. Calibrate a key to make sure that the new punch and die assembly is installed properly ([page 3-16](#)).

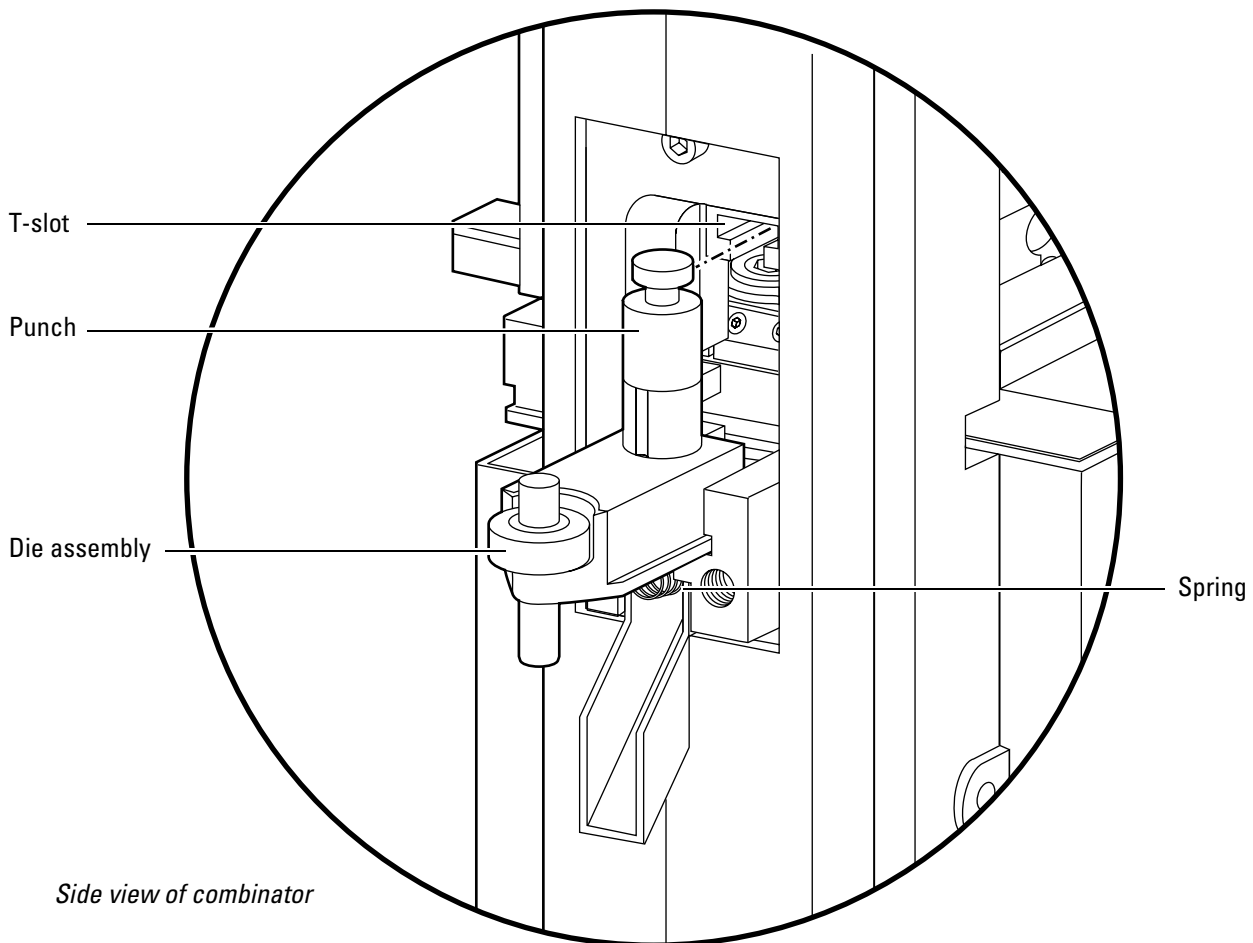

Figure 3.8 Inserting the punch into the T-slot

Replacing the key carriage

To perform any service to the key carriage, the operating lever must be in the upright position.

To remove the key carriage:

1. Using a 1/8" Allen wrench, unscrew the two fastener screws at the rear of the key carriage. Remove the rear stop plate from the back of the key carriage, as shown in [Figure 3.9](#).
2. From the front of the combinator, grip the key clamp knob and pull the key carriage out of the combinator. See [Figure 3.10](#).

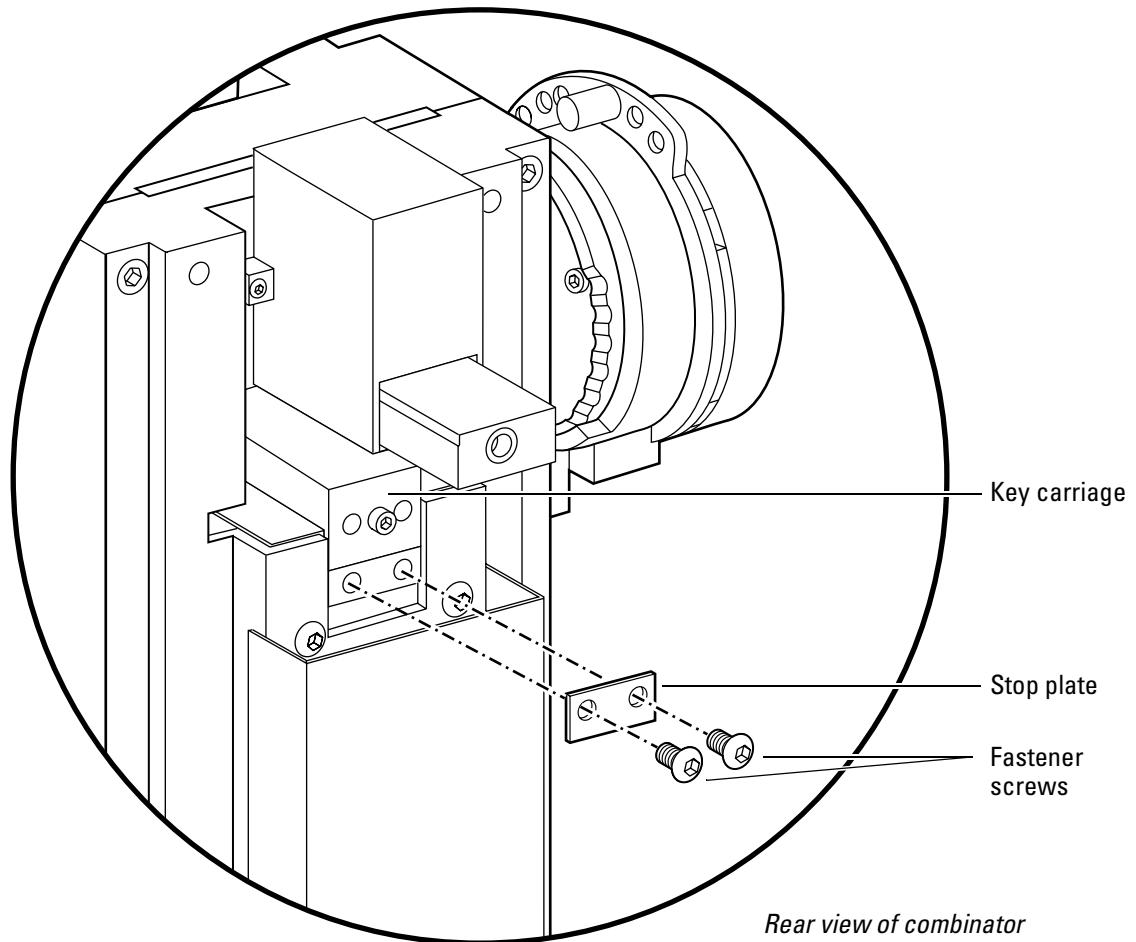

Figure 3.9 Removing the key carriage

To reinstall the key carriage:

1. Wipe off any excess grease and oil from the key carriage. Wipe off any chips that have built up inside the combinator or on the key stop area.
2. Lightly lubricate both the right and left sides of the key carriage (page 3-28).

Note: Use only a #10 non-detergent motor oil.

3. Carefully slide the key carriage into the slots on each side of the top plate assembly. See Figure 3.10.

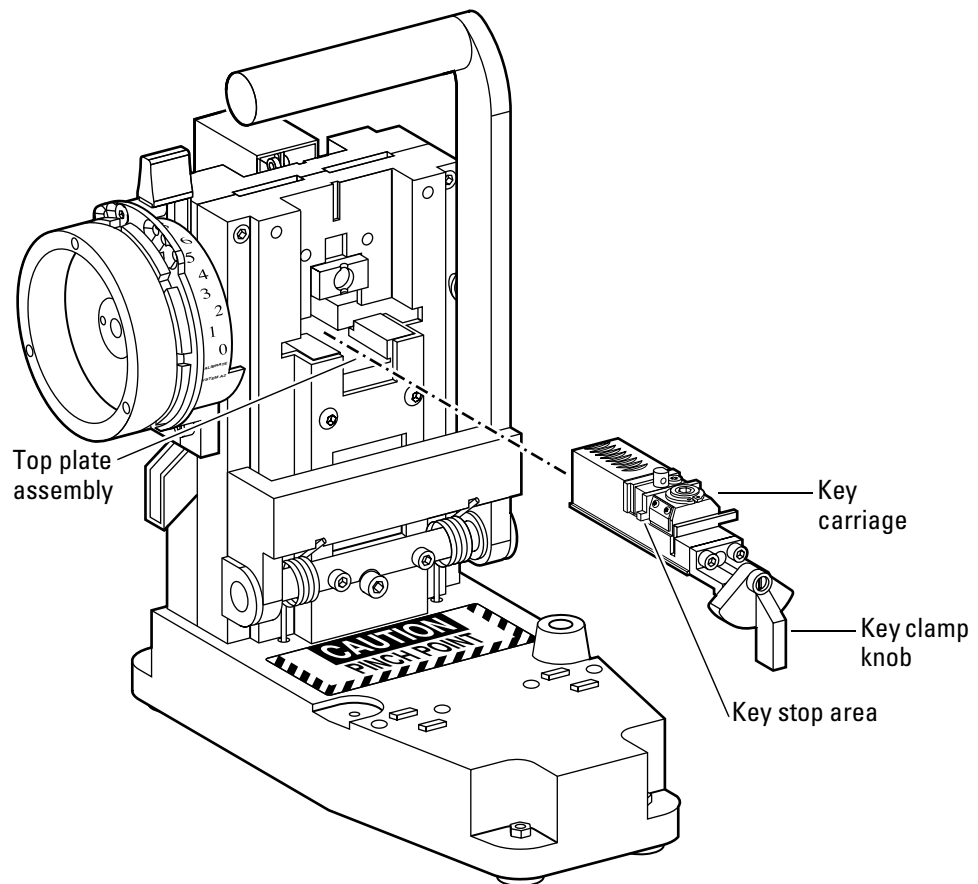

Figure 3.10 Reinstalling the key carriage

4. Locate the spring-loaded plungers along the side rail of the top plate. See Figure 3.11.
5. From the rear of the combinator, press in each spring-loaded plunger with a screwdriver so that the key carriage can slide past. See Figure 3.11.



Caution

Be careful not to damage the spring-loaded plungers when pressing against them with a screwdriver.

6. With the key carriage in place, install the rear stop plate with the two fastener screws onto the back of the key carriage. Secure the screws using a 1/8" Allen wrench.
7. Calibrate a key to make sure the new key carriage is properly installed ([page 3-16](#)).

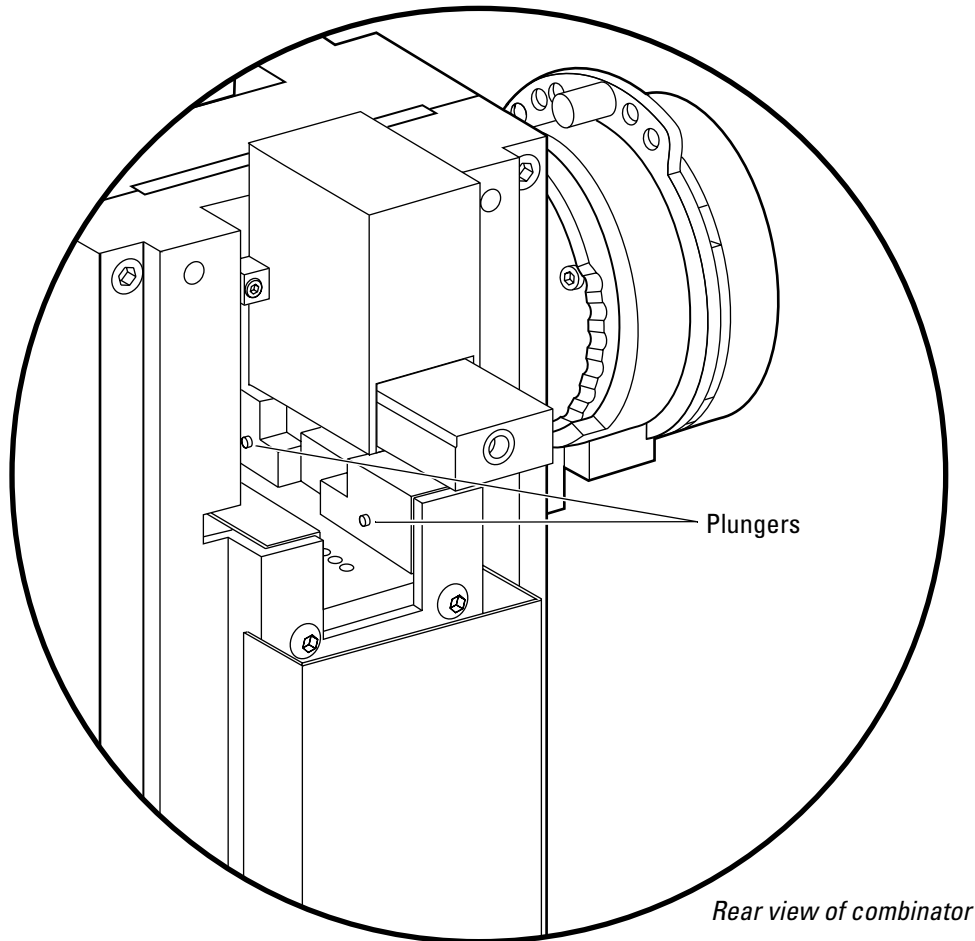

Figure 3.11 Depressing the key carriage plungers

Replacing the operating lever

To remove the operating lever:

1. Make sure that the key carriage is pushed completely into the key combinator housing.
2. Using a 5/32" Allen wrench, remove the two front screws on the operating lever frame. Save the screws.
3. Pull down the operating lever so that it rests against the rubber bumper on its own. See [Figure 3.12](#).

4. Pull the base of the operating lever assembly up and out of the key combinator housing.



Keep your fingers away from the springs when removing this assembly. The operating handle is spring-loaded, and springs will disengage and could scratch your fingers.

5. Using circlip pliers, insert the plier prongs into the holes of the retainer ring that is wrapped around the lever pin. You can remove the retainer ring on either side of the lever pin. See [Figure 3.12](#).



Be careful not to distort the shape of the retainer ring when removing it. Doing so can permanently damage the retainer ring, causing the operating lever to malfunction.

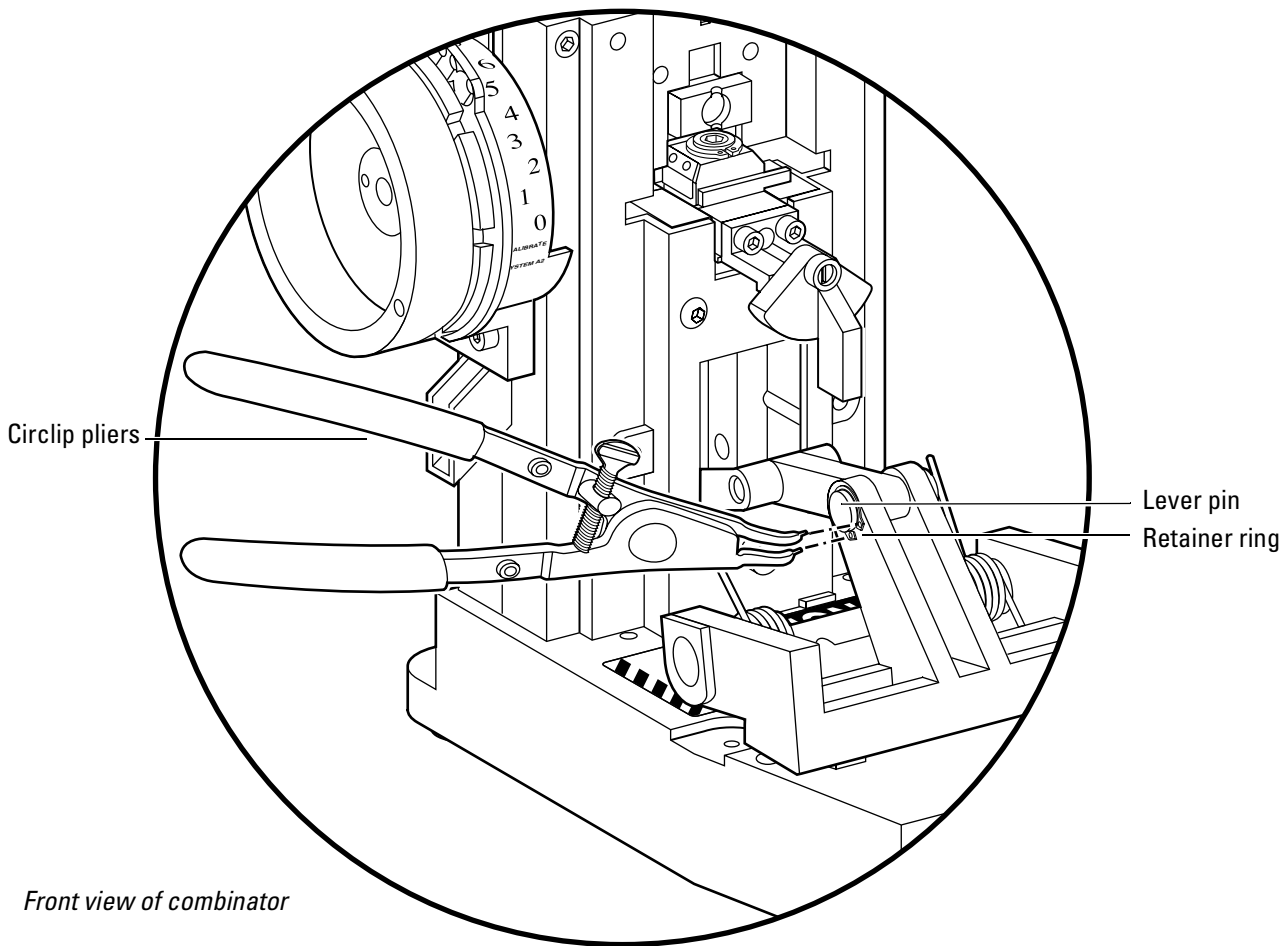
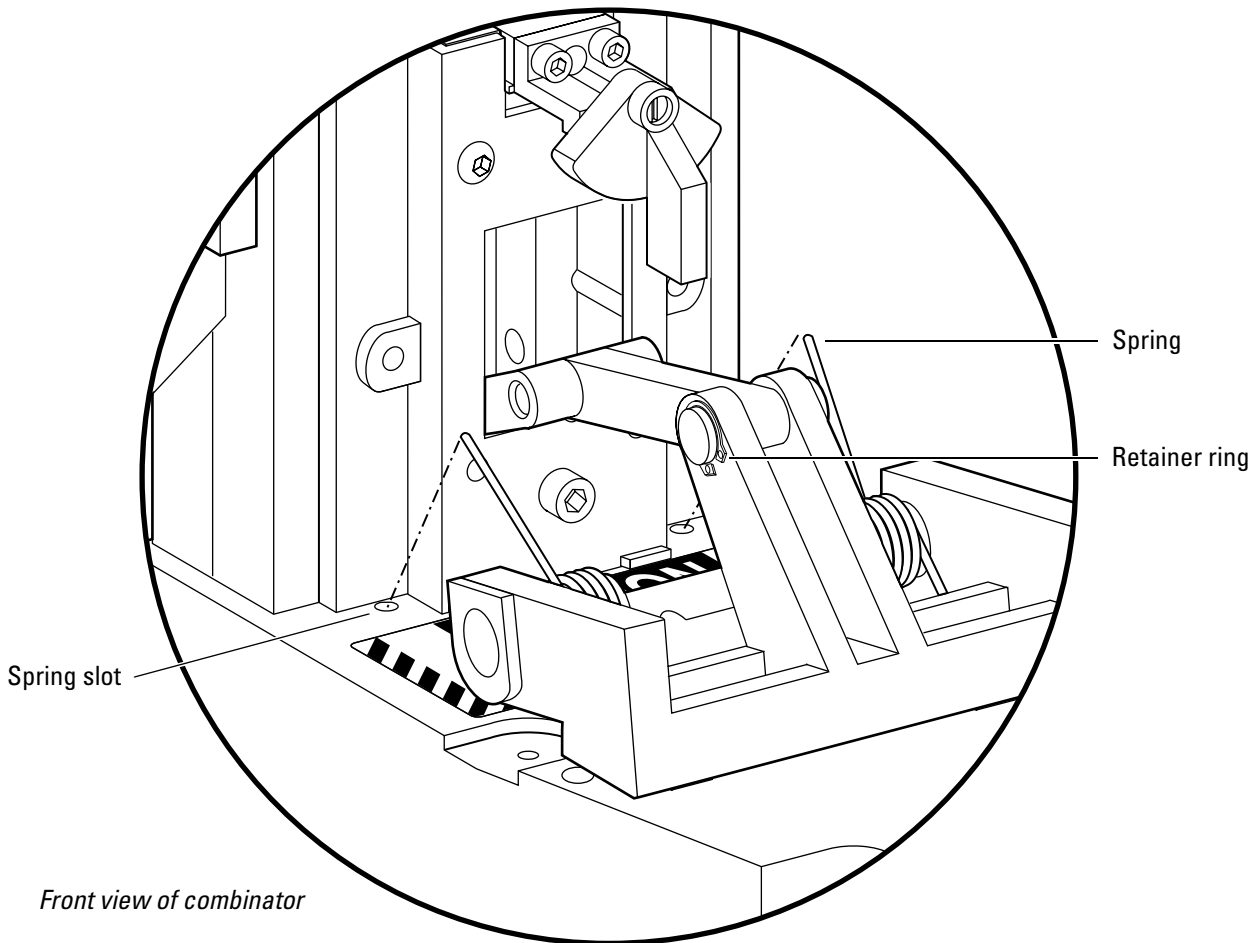

Figure 3.12 Removing the operating lever

6. Remove the retainer ring. Save the retainer ring.
7. Slide the lever pin out of the operating lever assembly. Save the lever pin.
8. Remove the operating lever.

To reinstall the operating lever:

1. With the operating handle resting on the key combinator base, align the holes in the operating lever with the holes on the lever branch and slide the lever pin into position. The lever pin may be difficult to insert in the holes. See [Figure 3.12](#).
2. Using the circlip pliers, place the retainer ring around the lever pin and secure the retainer ring in place. See [Figure 3.12](#).
3. Adjust the springs so the ends fit into the spring holes on the base of the combinator housing. See [Figure 3.13](#). Place the other ends of the springs into the spring slots on the operating lever frame.

**Figure 3.13** Reinstalling the operating lever

4. With the springs in place, push the operating lever assembly back into the key combinator housing so that the operating handle is upright and resting against the combinator frame.



When pushing the assembly back into the combinator housing, keep your fingers away from the springs so your fingers do not get pinched.

5. Using a 5/32" Allen wrench, install the two front screws and tighten until the operating handle is properly aligned.

CALIBRATING THE KEY COMBINATOR

Occasionally you will need to calibrate your combinator's cutting depth to make sure that keys are being cut properly.

Cutting a calibration key

To cut a calibration key:

1. Gripping the key clamp knob, pull the key carriage completely forward.
2. Turn the key clamp knob counterclockwise to open the key clamp spring (for left-handed combinator, turn the key clamp knob clockwise). See [Figure 3.2 \(page 3-4\)](#).
3. With the curved edge of the key blank against the locating surface, slide the key blank into the key opening. Make sure that the knife edge of the key clamp spring fits into the groove of the key. See [Figure 3.3 \(page 3-5\)](#).
4. Turn the key clamp knob clockwise, locking the key blank into the key carriage (for left-handed combinator, turn the key clamp knob counterclockwise).

The key clamp knob hangs loosely in the six o'clock position, as shown in [Figure 3.3 \(page 3-5\)](#).

5. Move the dial on the depth selector assembly to the “CALIBRATE” line, which is located below “0”, as shown in [Figure 3.14](#).

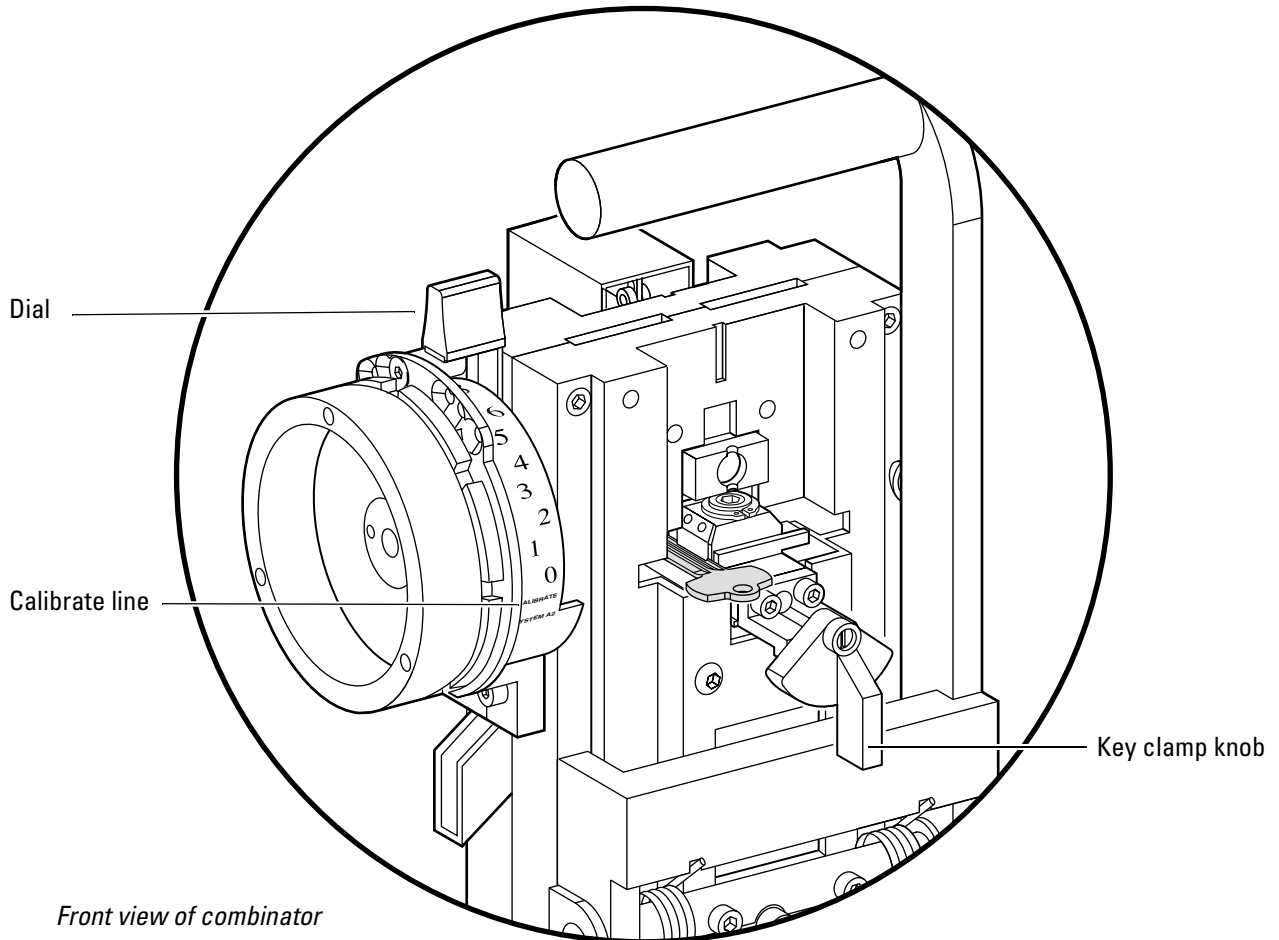

Figure 3.14 Cutting a calibration key

6. Pull the operating lever down firmly until it strikes the rubber bumper; then, let the operating lever move back to its original position.

Note: The first stroke of the operating lever does not make a keycut; it only moves the key into proper position for the first cut.

The key carriage and key blank are now in place for the first cut.

7. With the depth selector still set to “CALIBRATE,” pull the operating lever down firmly until it strikes the rubber bumper; then, let the operating lever move back to its original position.

The combinator makes the first cut and automatically moves the key carriage and key blank into place for the next cut.

8. Repeat Step 7 until you have made all seven cuts on the key at calibration depth.
9. Gripping the key clamp knob, pull the key carriage completely forward.

10. Turn the key clamp knob counterclockwise (for left-handed combinators, turn the key clamp knob clockwise).
11. Slide the key out.

Placing the key in the gauge

To place the key in the gauge:

1. Insert the blade of the key into the key gauge frame. Secure the key so that the key blade is flat against the back of the frame, and the bottom of the key is against the base of the frame.
2. Adjust the key so that the spindle is centered in between the third and fourth keycut, as shown in [Figure 3.15](#).

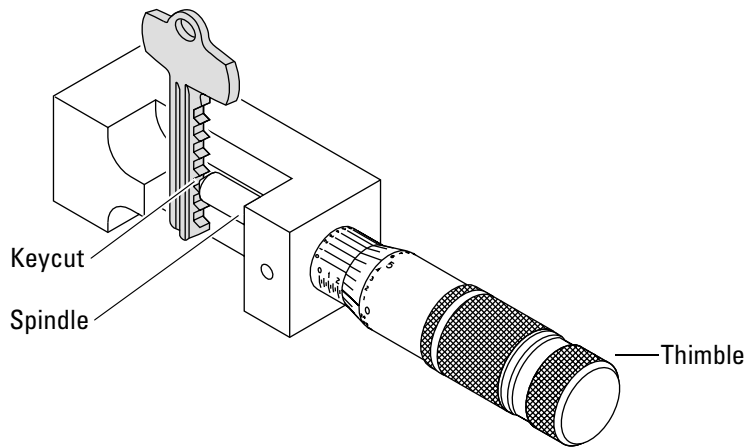

Figure 3.15 Inserting a key into the key gauge

3. Grip the thimble and slowly turn it clockwise to move the spindle towards the key. When the spindle is touching the key and will not go any closer, the key gauge produces a “clicking” sound; you can stop turning the thimble.

Reading the gauge

If you have an AD502D digital key gauge, read the measurement displayed on the screen and skip to the section “Checking the measurement.” For a manual key gauge, refer to [Figure 3.16](#) and perform the steps below.

To read the key gauge:

1. On Scale 1, read the largest visible number. Each number on Scale 1 stands for 0.100” (one hundred thousandths of an inch). Each line on Scale 1 stands for 0.025” (twenty-five thousandths of an inch).
2. On Scale 1, count the number of lines between the largest number and the end of the thimble.
3. On Scale 2, read the largest number that is even with or just below the centerline of Scale 1. Each line on Scale 2 stands for 0.001” (one thousandth of an inch).

4. On Scale 3, read the line that best aligns with a line on Scale 2. Each line on Scale 3 stands for 0.0001" (one ten-thousandth of an inch).

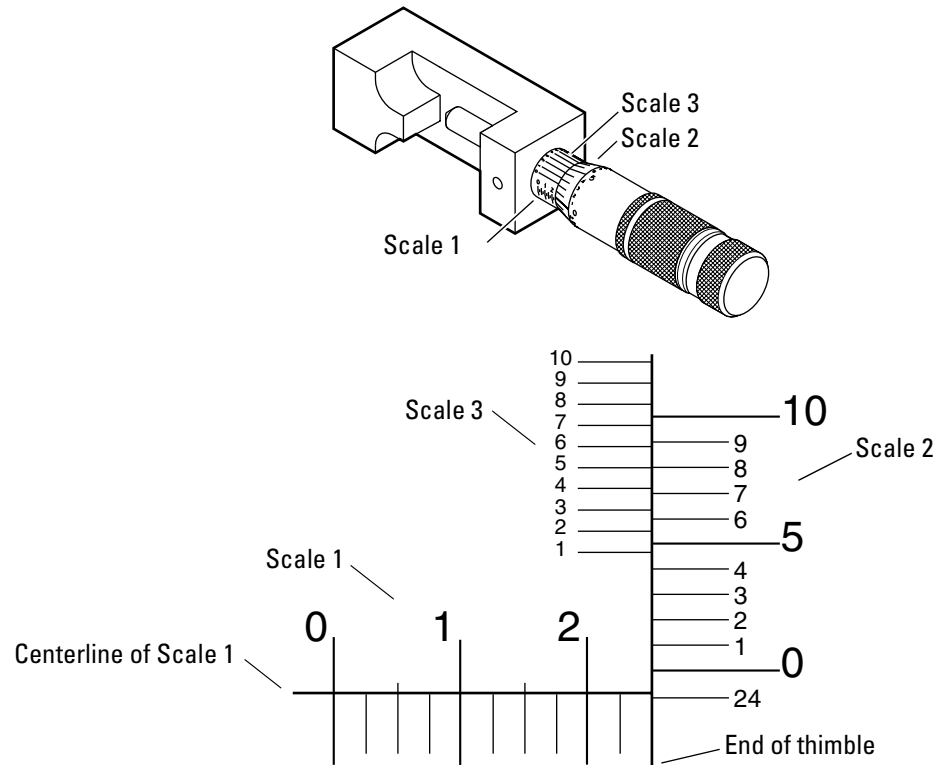

Figure 3.16 Calibration measurement scale

Totaling the measurement

To find the depth of the keycut, add the values from the three scales. The table below shows an example.

Step	Scale	Reading	Number	Value
1	1	Largest number visible	2	0.2000"
2	1	Number of visible lines between the largest number and the thimble	1	0.0250"
3	1 and 2	Largest number on scale 2 that is even with or below the centerline of scale 1	24	0.0240"
4	2 and 3	Line on scale 3 that best aligns with a line on scale 2	5	0.0005"
Total:				0.2495"

Checking the measurement

For each of the masterkey systems, the target calibration measurement is 0.2500". However, the key combinator is still considered to be within the calibration range if your measurement is between 0.2490" and 0.2510".

If your keycut measurement falls within this range, the key combinator does not need adjustment. If your measurement is outside this range, you need to adjust the depth selector or contact your BEST Representative.

Adjusting the depth selector

To adjust the depth selector for a micrometer reading measuring *less* than 0.2490”:

1. With a lead or grease pencil, mark a straight line across the depth selector assembly. See [Figure 3.17](#).

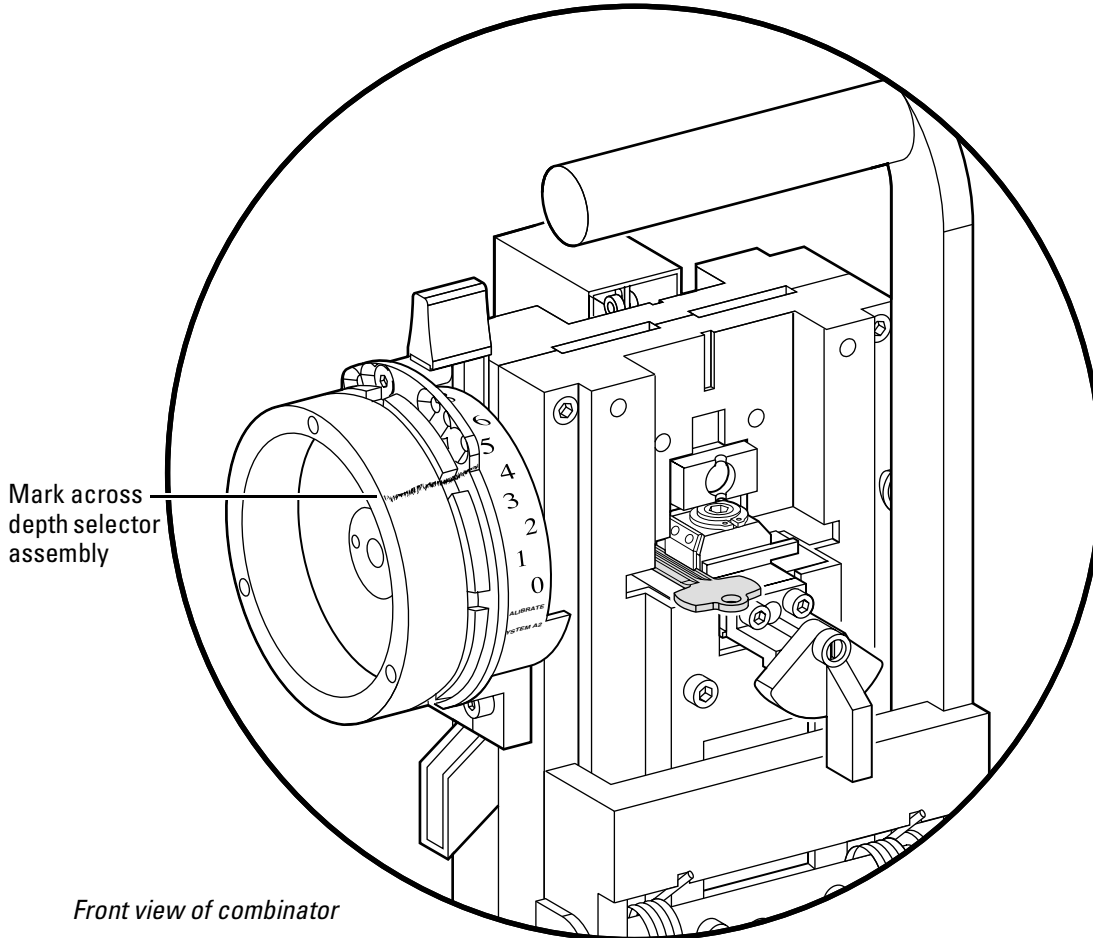

Front view of combinator

Figure 3.17 Marking the depth selector assembly

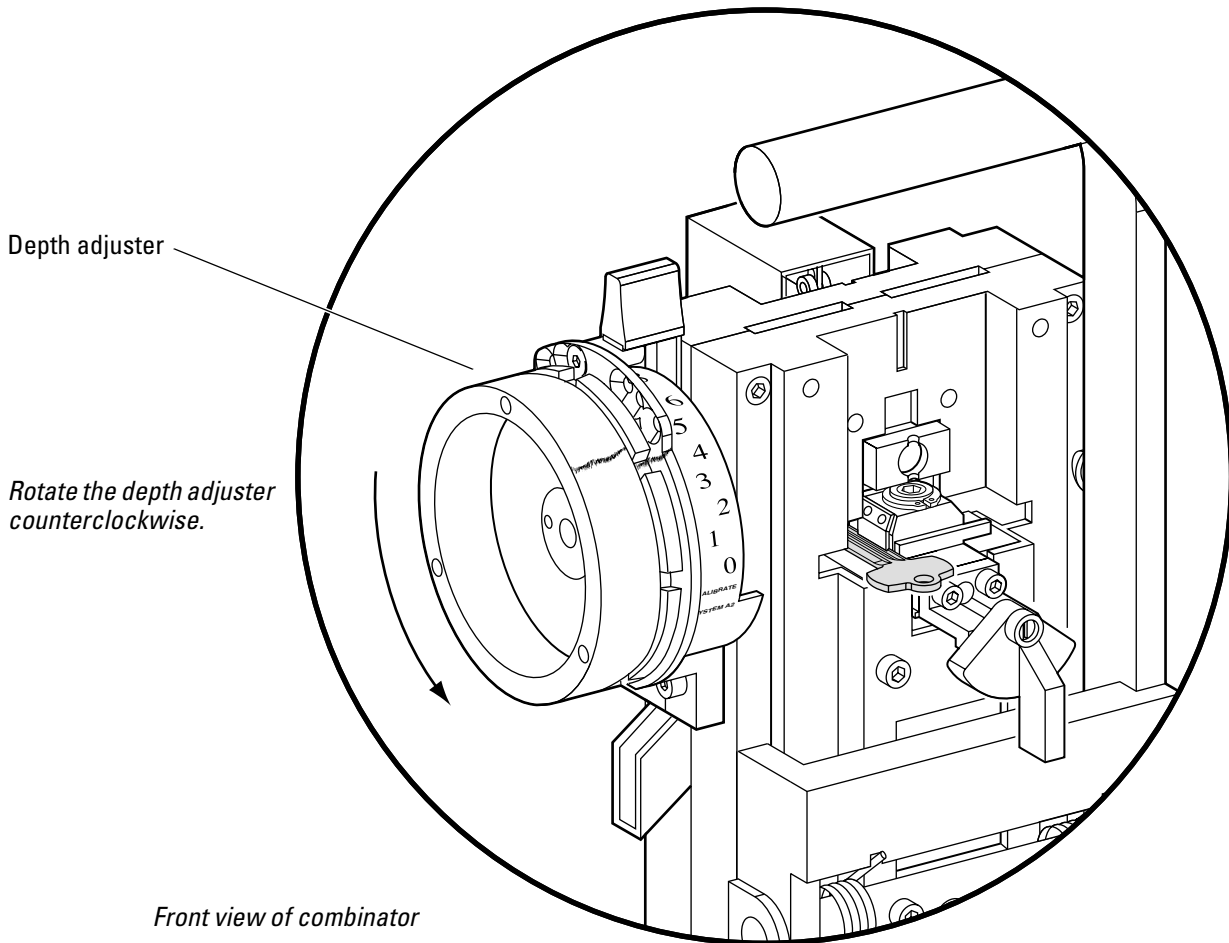

Front view of combinator

Figure 3.19 Turning the depth adjuster counterclockwise

4. While holding the depth adjuster in place, tighten the spanner nut.
If the depth adjuster moves while you are tightening the spanner nut, go to Step 5. Otherwise, go to Step 6.
5. If the depth adjuster moves while you are tightening the spanner nut:
 - Loosen the spanner nut again.
 - Return the depth adjuster to its original position, using the lead or grease mark as your reference.
 - Repeat Step 2 through Step 4.
6. Perform the following steps:
 - Cut the calibration key ([page 3-16](#)).
 - Place the key in the gauge ([page 3-18](#)).
 - Read the gauge ([page 3-18](#)).
 - Total and check the measurement ([page 3-19](#)).

Note: The new keycut depth should be within calibration range. If not, send the key combinator to the BEST factory for repair.

To adjust the depth selector for a micrometer reading measuring *more than 0.2510"*:

1. With a lead or grease pencil, make a mark across the depth selector assembly. See [Figure 3.17](#).
2. While holding the depth adjuster in place, use the spanner wrench to loosen the spanner nut. See [Figure 3.18](#).
3. Rotate the depth adjuster clockwise (turning the depth adjuster 1/4" changes the cut depth by 0.0010"—one thousandth of an inch). Use the lead or grease mark as a reference. See [Figure 3.20](#).

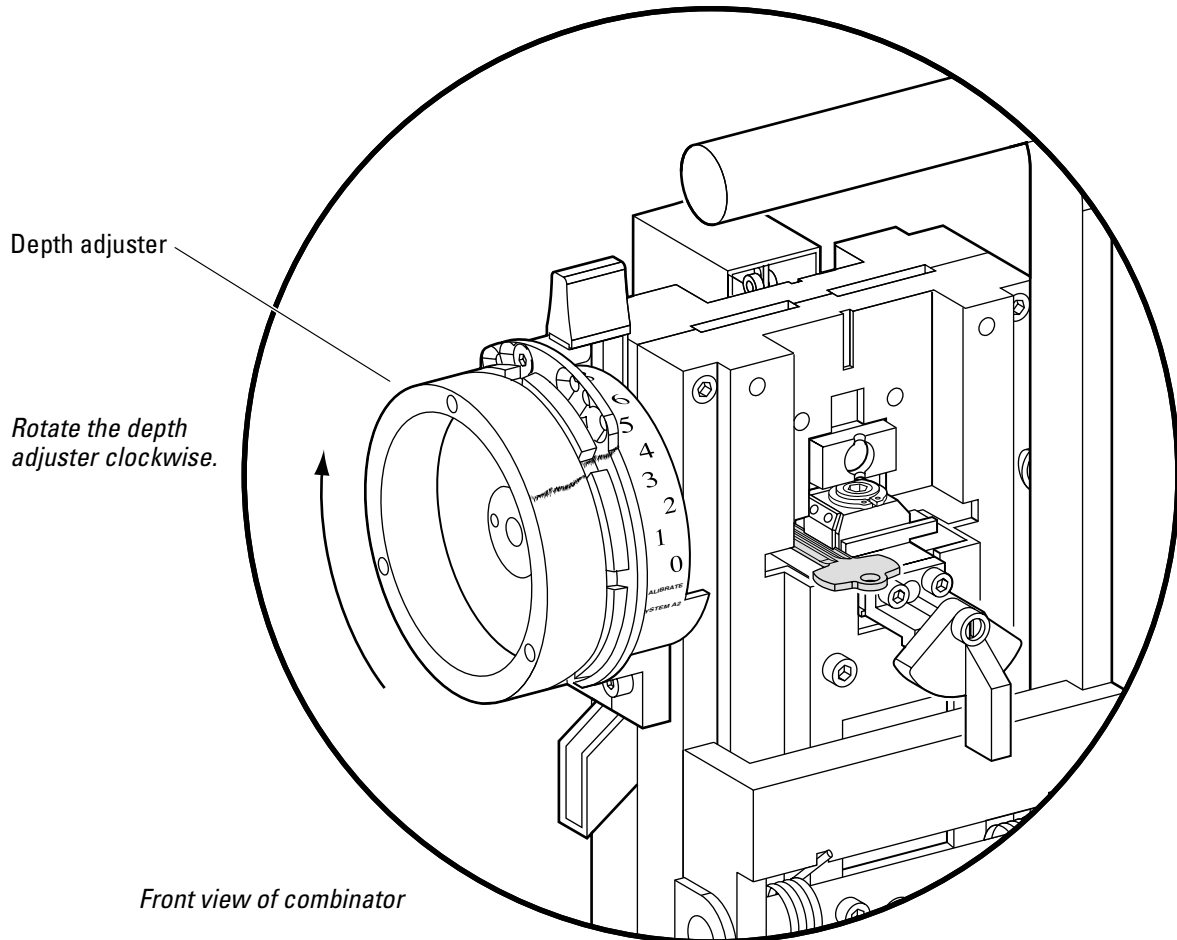

Figure 3.20 Turning the depth adjuster clockwise

4. While holding the depth adjuster in place, tighten the spanner nut. *If the depth adjuster moves while you are tightening the spanner nut, go to Step 5. Otherwise, go to Step 6.*

5. If the depth adjuster moves while you are tightening the spanner nut:
 - Loosen the spanner nut again.
 - Return the depth adjuster to its original position, using the lead or grease mark as your reference.
 - Repeat Step 2 through Step 4.
6. Perform the following steps:
 - Cut the calibration key ([page 3-16](#)).
 - Place the key in the gauge ([page 3-18](#)).
 - Read the gauge ([page 3-18](#)).
 - Total and check the measurement ([page 3-19](#)).

ADJUSTING THE KEY CLAMP SPRING

Because keys may vary slightly in thickness, you may need to occasionally adjust the key clamp spring to make sure that keys are properly clamped in the key carriage.

If your key is either difficult to insert or too loose to clamp into place, perform the following steps.

To adjust the key clamp spring:

1. Gripping the key clamp knob, pull the key carriage completely forward.
2. Raise the key clamp spring by turning the key clamp knob counterclockwise, as shown in [Figure 3.21](#) (for left-handed combinators, turn the key clamp knob clockwise).
3. Slide a key blank into the key carriage.

If the key is difficult to insert, go to Step 4a.

If the key is too loose to clamp in place, go to Step 4b.

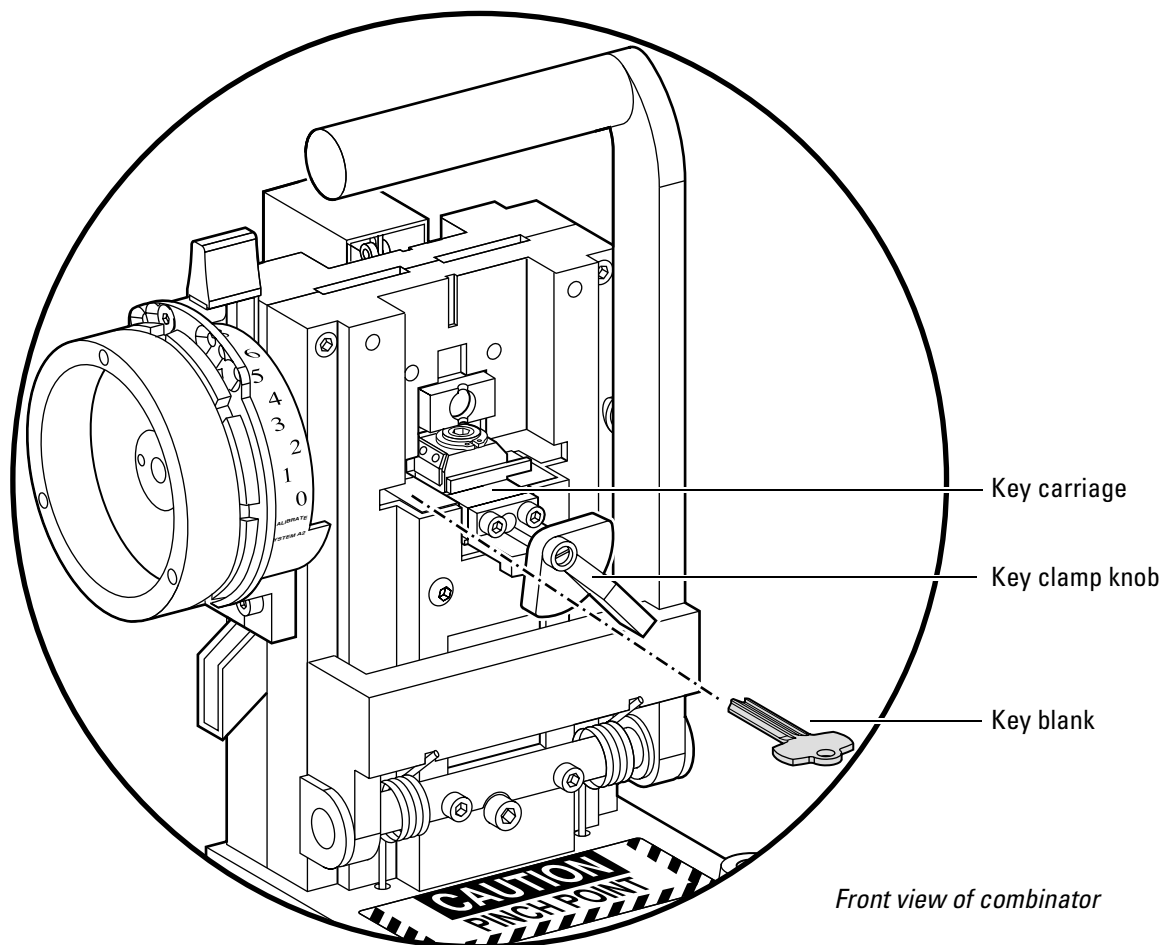

Figure 3.21 Loading a key

4a. If the key is difficult to insert, use a 5/32" Allen wrench to turn the adjustment screw clockwise, in 30° increments, until you achieve the appropriate insertion force. You may need to pull the operating lever down slightly to properly position your Allen wrench. See [Figure 3.22](#). A small amount of drag on the key is needed.

Go to Step 5.

4b. If the key is too loose to clamp in place, use a 5/32" Allen wrench to turn the adjustment screw counterclockwise, in 30° increments, until you achieve the appropriate insertion force. You may need to pull the operating lever down slightly to properly position your Allen wrench. See [Figure 3.22](#). A small amount of drag on the key is needed.

Go to Step 5.

5. Turn the key clamp knob completely clockwise to clamp the key blank into the key carriage (for left-handed combinators, turn the clamp knob counterclockwise).

6. Calibrate a key to make sure the key clamp spring is properly adjusted ([page 3-16](#)).

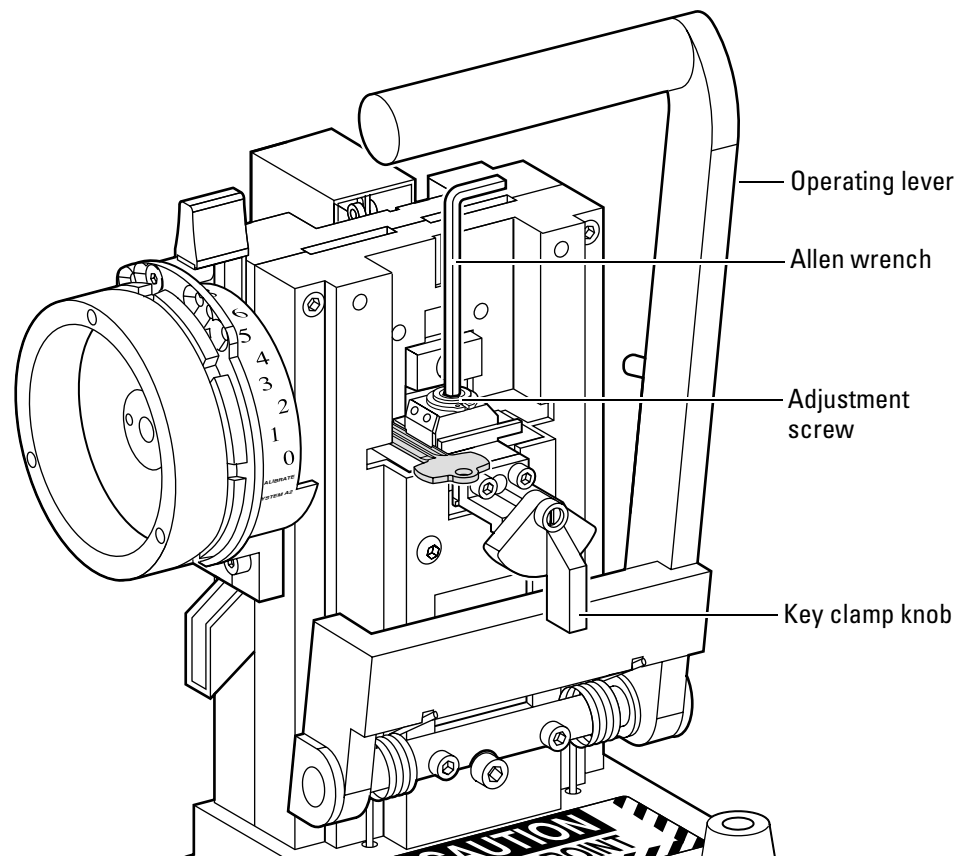

Figure 3.22 Adjusting the key clamp spring

PREVENTATIVE MAINTENANCE

Preventative maintenance is vital for keeping your key combinator functioning properly. To ensure accurate keycuts and avoid possible malfunctions, periodically perform the tasks below. It is also a good idea to keep your key combinator covered whenever it is not in use. Doing so will help keep dust and other foreign particles out of the crevices of the combinator.

To help maintain your key combinator, perform the following tasks:

- Clean (wipe down) the following items:
 - ▲ chip chute to remove metal chips
 - ▲ outside of key combinator to remove dust and other particles
 - ▲ key carriage compartment to remove dust and metal chips ([page 3-27](#))
 - ▲ punch and die compartment to remove dust and metal chips ([page 3-27](#)).
- Check for and tighten any loose screws.
- Adjust the key clamp spring as needed ([page 3-25](#)).
- Calibrate for consistency ([page 3-16](#)).
- Lubricate necessary parts ([page 3-28](#)).

See the *BEST Key Combinator Preventative Maintenance Record Sheet* in Appendix B of this manual to help you keep records of your maintenance tasks.

CLEANING PARTS

Cleaning the punch and die

To clean the punch and die:

1. Remove the depth selector ([page 3-7](#)).
2. Remove the punch and die assembly ([page 3-9](#)).
3. Wipe out any key chips and dust from the compartment. Do not lubricate this area.
4. Lubricate both sides of the die ([page 3-28](#)).
5. Reinstall the punch and die assembly ([page 3-10](#)).
6. Reinstall the depth selector ([page 3-8](#)).

Cleaning the key carriage

To clean the key carriage:

1. Remove the key carriage ([page 3-11](#)).
2. Wipe out any chips and dust from the compartment.
3. Lubricate both sides of the carriage ([page 3-28](#)).
4. Reinstall the key carriage ([page 3-11](#)).

LUBRICATING PARTS

It is important to lubricate your key combinator regularly with a quality #10 non-detergent motor oil. Signs that your combinator is overdue for lubrication include:

- squeaking sounds
- corrosion
- difficulty making keycuts
- tightness in moving the operating lever.

Guidelines for lubrication

To avoid damaging your combinator and causing inaccurate keycuts, please adhere to the following:

- Apply only enough oil to barely wet the appropriate points to avoid overlubricating your combinator.
- Do not lubricate the chip chute, the depth selector, or the roller on the punch and die. Chips could stick to these parts, causing malfunctions.
- Do not apply any type of silicone-based lubricant to your combinator. Doing so may void your warranty or service agreement.
- Do not use an air hose to remove chips or dust from the key combinator. Doing so may void your warranty or service agreement.

Lubricating the key combinator housing

To lubricate the outer frame/housing of the key combinator:

1. Apply one drop of oil into each of the upper front holes and rear holes. See [Figure 3.23](#).
2. Apply one drop of oil into the 3/8" diameter pin located above the adjustment screw.

To lubricate the key carriage:

1. Apply one drop of oil into the 1/4" diameter pin located on top of the key carriage.
2. Apply one drop of oil on both sides of the key carriage's sliding surfaces. See [Figure 3.23](#).

Slide the key carriage in and out as you lubricate.

To lubricate the operating lever:

1. Apply one drop of oil onto each side of the operating lever frame. See [Figure 3.23](#).
2. Apply one drop of oil onto the springs connected to the operating lever.
3. Apply one drop of oil to each of the other linkages that you can conveniently reach.

You need to pull down and hold the operating lever to reach some of these areas.

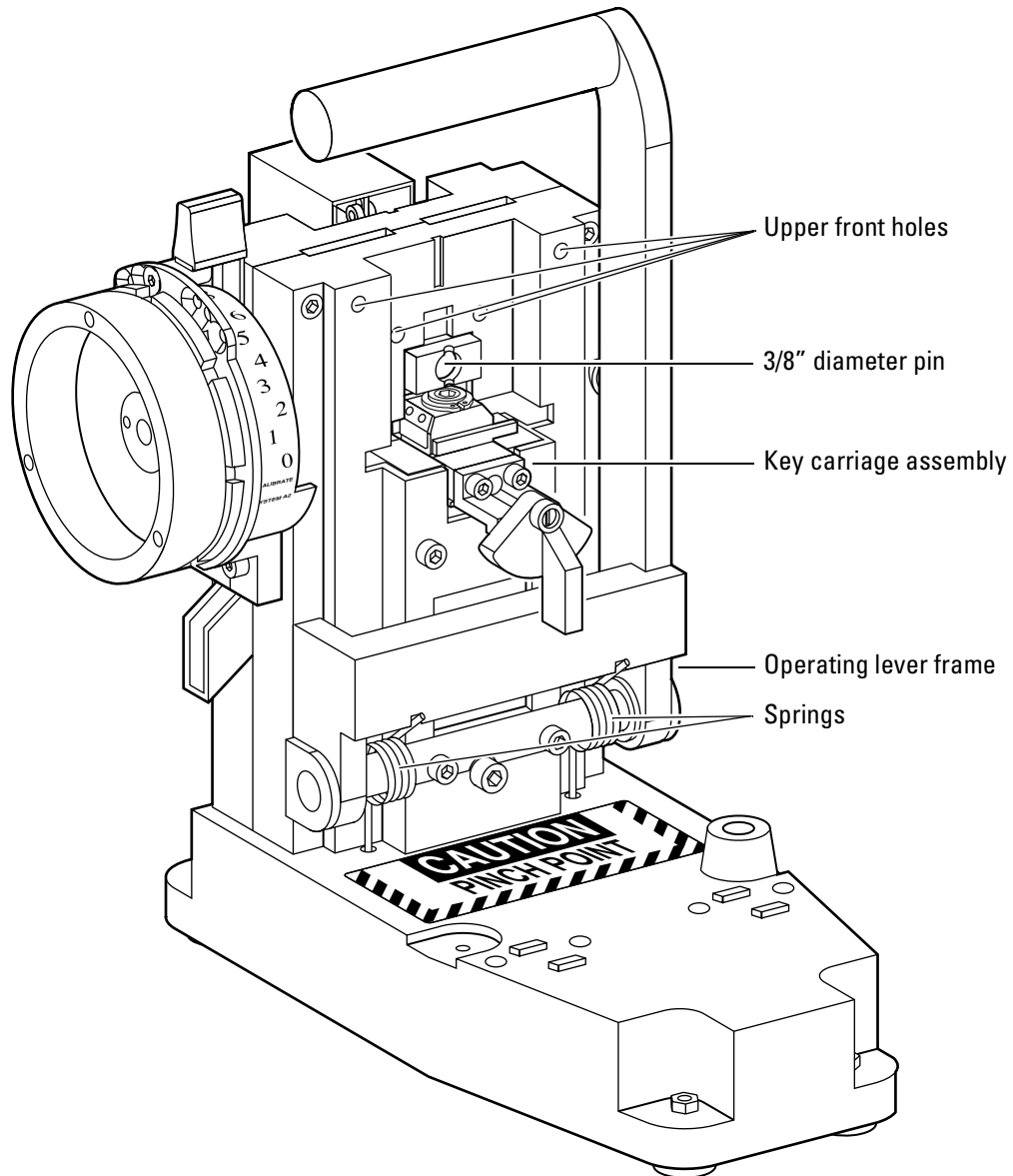

Figure 3.23 Lubricating parts

To lubricate the punch and die:

1. Remove the following items:
 - depth selector assembly (page 3-7)
 - punch and die assembly (page 3-9).
2. Apply one drop of oil each of the sides of the die block. See Figure 3.24. Do not lubricate the roller or the punch and die compartment.
3. Reinstall the following items:
 - punch and die assembly (page 3-10)
 - depth selector assembly (page 3-8).

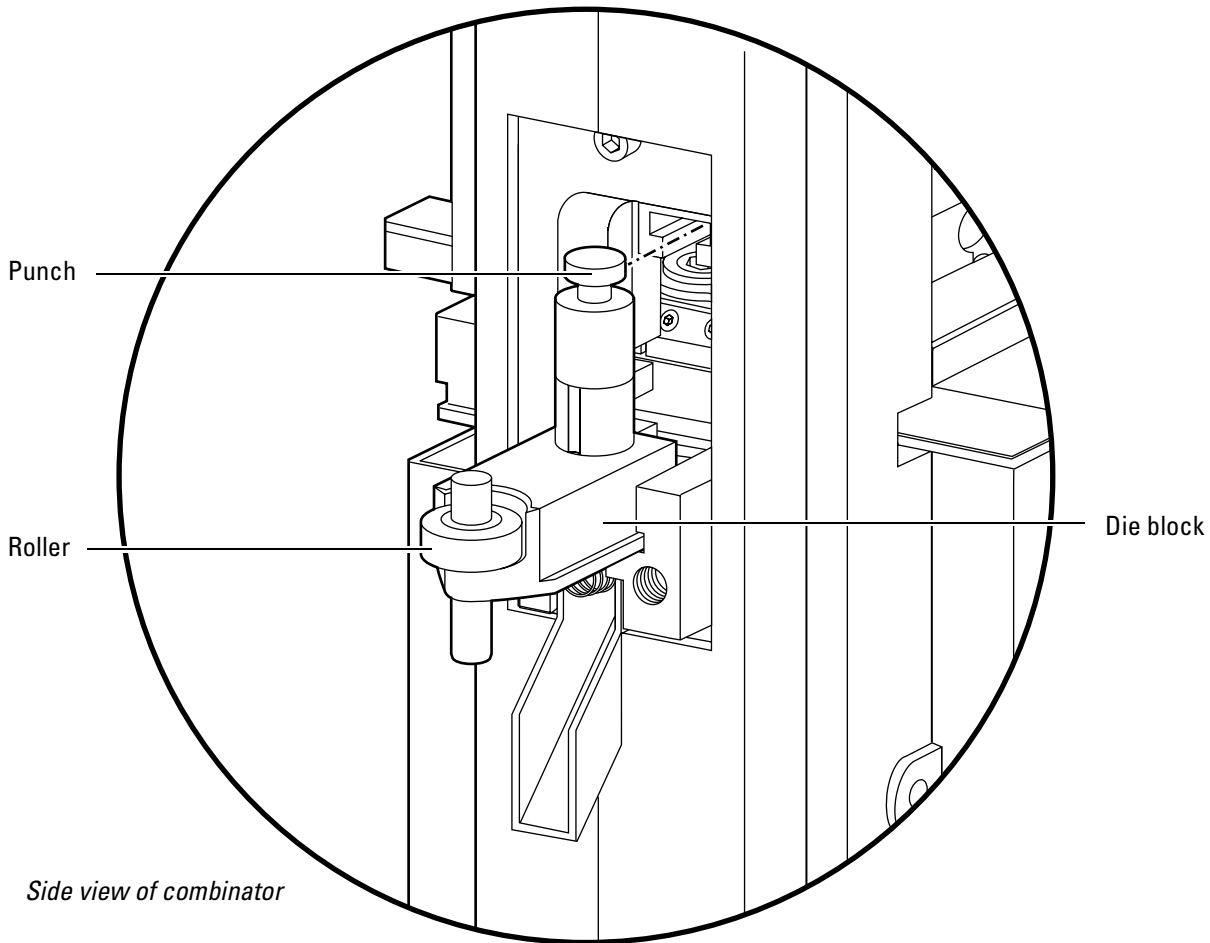

Figure 3.24 Lubricating the punch and die

TROUBLESHOOTING

This table summarizes the possible causes for the most common key combinator problems. The causes are listed in the order of likelihood. (The most likely cause is first, and so forth.)

You notice...	Possible causes include...	You should...
Key is difficult to insert in the key combinator.	<ul style="list-style-type: none"> a. Key clamp spring is closed. b. Key clamp spring needs to be adjusted. 	<ul style="list-style-type: none"> a. Turn the key clamp knob to open the key clamp spring. b. Adjust the key clamp spring until the key feels tightly secured in the key carriage (page 3-25).
Key is loose in the key carriage.	<ul style="list-style-type: none"> a. Key clamp spring is open. b. Key clamp spring needs to be adjusted. 	<ul style="list-style-type: none"> a. Turn the key clamp knob to close the key clamp spring. b. Adjust the key clamp spring until the key feels tightly secured in the key carriage (page 3-25).
Depth selector is jammed or will not allow selection of deeper cuts.	Chips are lodged in the guide rails.	Remove the punch and die and clear away the chips from the guide rails (page 3-27).
There is a burr in the keycut.	<ul style="list-style-type: none"> a. Handle was not depressed completely. b. Punch and die are worn. 	<ul style="list-style-type: none"> a. Recut the key (page 3-4). b. Replace the punch and die (page 3-9).
Keycut depth is incorrect.	<ul style="list-style-type: none"> a. Depth selector was not released when the cut was made. b. Cutting depth needs to be calibrated. c. There are chips on the depth selector. d. There are chips on the die assembly roller. 	<ul style="list-style-type: none"> a. Follow the steps for cutting keys (page 3-4). b. Calibrate the depth of the cut (page 3-16). c. Remove the depth selector (page 3-7) and clear away the chips. d. Remove the depth selector (page 3-7) as well as the punch and die (page 3-9). Clear away the chips.
Operating handle is difficult to pull down.	<ul style="list-style-type: none"> a. Retainer ring is hyper extended. b. Operating lever needs to be lubricated. 	<ul style="list-style-type: none"> a. Replace the retainer ring. b. Lubricate the lever handle (page 3-29).
Keycut spacing is incorrect.	Key carriage does not move or moves inconsistently.	Remove the key carriage and clear away any chips. If the problem persists, return the combinator to BEST for repair.

A

GLOSSARY

Calibrate	To check against a known standard and adjust to that standard.
Calibration depth	Standard keycut measurement (.2500") that the key combinator should cut when the calibration position is selected.
Calibration position	Position on the depth selector that, when selected, sets up the key combinator to cut the calibration depth keycut.
Core	See interchangeable core.
Depth selector	Dial on the key combinator, marked with numbers, that is used for selecting keycut depths.
Figure-8	Shape of the interchangeable core and its housing (housings include door knob, cylinder, padlock, and so forth).
Interchangeable core	Figure-8 shaped device that contains all the mechanical parts for a masterkey system. The interchangeable core can be removed with a special control key and recombined without disassembling the lock.
Key blank	Key with a keyway shape, but without keycuts.
Key carriage	Housing that moves the key to each keycut position.
Key clamp knob	Knob that operates the key clamp spring and that is used to pull out or push in the key carriage.
Key clamp spring	Part of the key combinator that holds the key in place.

Key combinator	Machine that notches cuts into BEST key blanks for BEST masterkey systems.
Keycut	Notch in a key that fits a corresponding pin segment of a core.
Keycut depth	Distance from the bottom of the keycut to the underside of the key blade.
Key gauge	AD502 gauge that measures keycut depths. This gauge is used to calibrate the key combinator.
Keying system	Method of keying locks.
Keyway	Cross-section shape milled into the key blank and broached into core plugs.
Left-handed key combinator	Key combinator that cuts only patented or left-handed premium keys.
Masterkeying	Process of combining locks to allow a single key to operate many locks and to allow each lock to be operated by a unique key at the same time.
Punch and die	Part of the key combinator that notches keys to a precise shape.
Right-handed key combinator	Key combinator that cuts only standard or right-handed premium keys.
Setup stroke	First stroke of the operating lever that positions the key for cutting.

B

PREVENTATIVE MAINTENANCE

Use the following page to record periodic cleaning and maintenance tasks that are performed on your key combinator. The frequency with which you perform these tasks may vary based on your specific needs.

BEST Key Combinator Preventative Maintenance Record Sheet

Record date and initial when task is completed

Task	Date:	Date:	Date:	Date:	Date:	Date:	Date:	Date:	Date:	Date:	Date:	Date:	Date:	Date:	Date:	Date:	Date:	Date:	Date:	Date:
	By:	By:	By:	By:	By:	By:	By:	By:	By:	By:	By:	By:	By:	By:	By:	By:	By:	By:	By:	By:
Clean and dust the outside of the combinator																				
Clean the key carriage																				
Clean the punch and die																				
Lubricate the necessary parts																				
Calibrate for consistency†																				

† Calibrate whenever you service your key combinator as well.

C

INDEX

A

- adjusting the depth selector
 - for key cut measuring less than 0.2490"
3-20
 - for key cut measuring more than 0.2510"
3-23
- adjusting the key clamp spring 3-25

C

- calibrating
 - checking the measurement 3-19
 - cutting the key 3-16
 - placing the key in the gauge 3-18
 - reading the gauge 3-18
 - totaling the measurement 3-19
- circlip pliers 3-2
- cleaning
 - general tips 3-27
 - key carriage 3-27
 - punch and die 3-27

D

- depth selector
 - A2 assembly 2-2 to 2-3
 - A3 assembly 2-2 to 2-3
 - A4 assembly 2-2 to 2-3
 - adjusting 3-20
 - reinstalling 3-8
 - removing 3-7
- documentation package
 - see technical documentation package
- drawings, of parts
 - see part numbers and drawings

E

- exploded diagrams
 - see part numbers and drawings

K

- key calibration gauge 3-2
- key carriage
 - 6-pin Peaks assembly 2-2
 - 7-pin Peaks assembly 2-2
 - cleaning 3-27
 - lubricating 3-28
 - premium assembly 2-2 to 2-3
 - reinstalling 3-12
 - removing 3-11
 - standard assembly 2-3
- key clamp spring, adjusting 3-25
- keys
 - cutting 3-5
 - loading 3-4
 - patented key 2-4
 - premium key 2-4
 - standard key 2-4
 - unloading 3-6
- keyways 2-5

L

- lubricating
 - combinator housing 3-28
 - guidelines to follow 3-28
 - key carriage 3-28
 - operating lever 3-29
 - punch and die 3-30

M

machine handing [3-2](#)
maintenance, preventative
 general tasks [3-27](#)
 record sheet [B-2](#)

N

numbers, for parts
 see part numbers and drawings

O

operating lever
 lubricating [3-29](#)
 reinstalling [3-15](#)
 removing [3-13](#)
 standard assembly [2-2](#) to [2-3](#)

P

part numbers and drawings
 for circlip pliers [3-2](#)
 for key calibration gauge [3-2](#)
 for left-handed key combinator
 [2-2](#)
 for patented key [2-4](#)
 for premium key [2-4](#)
 for right-handed key
 combinator [2-3](#)
 for spanner wrench [3-2](#)
 for standard key [2-4](#)
product family diagram [1-2](#)
punch and die
 cleaning [3-27](#)
 lubricating [3-30](#)
 Peaks assembly [2-2](#)
 reinstalling [3-10](#)
 removing [3-9](#)
 standard assembly [2-2](#) to [2-3](#)

R

reinstalling
 depth selector [3-8](#)
 key carriage [3-12](#)
 operating lever [3-15](#)
 punch and die [3-10](#)
removing
 depth selector [3-7](#)
 key carriage [3-11](#)
 operating lever [3-13](#)
 punch and die [3-9](#)

S

spanner wrench [3-2](#)
support, technical
 see technical support

T

technical documentation package
 [1-3](#)
technical support [1-3](#)
troubleshooting [3-25](#)