

1 Insert the key

- 1 With the machine bolted down or free standing, you can start cutting keys. See Figure 1 to locate key combinator parts.

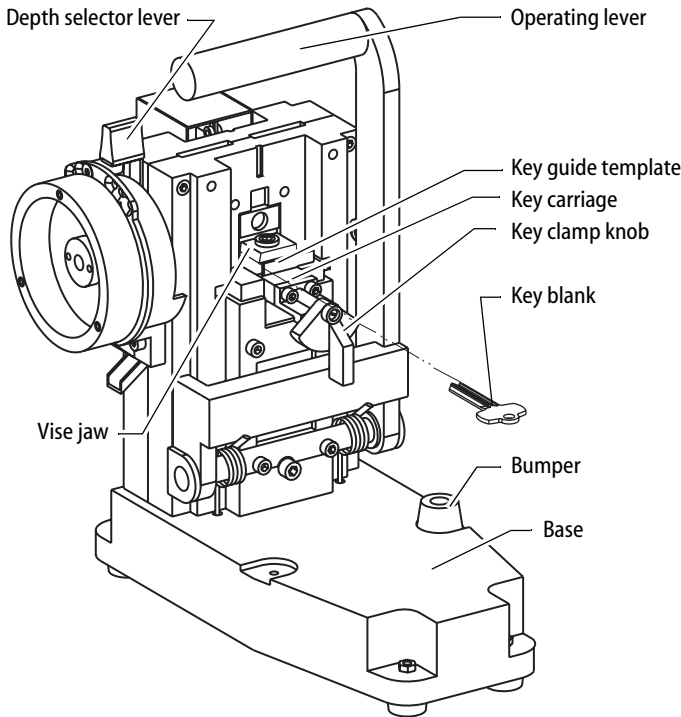

Figure 1 Right-handed key combinator with various parts labeled

Caution: Always keep fingers and hands out of the way of moving parts. Be especially careful of the pinch point between the base and operating lever.

Note: The operating lever must be pointing up when you load or unload a key.

- 1 Pull the key clamp knob until the key carriage stops and is all the way out.
- 2 Turn the key clamp knob counterclockwise to open the vise jaw. For left-handed machines, turn the key clamp knob clockwise.
- 3 With the curved-edge of the key blank against the locating surface (see Figure 2), slide the key blank into the guide template opening until it stops. Make sure that the knife edge of the vise jaw fits into the groove of the key.

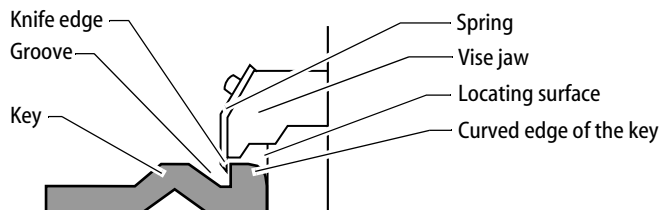

Figure 2 Proper position of a key in the vise jaw—as seen from the front of the key combinator

- 4 Turn the key clamp knob clockwise, locking the key blank into the key carriage. For left-handed machines, turn the key clamp knob counterclockwise.

When the knob becomes free, about the six o'clock position, the key is locked in the carriage.

2 Cut the key

Note: Make sure the key carriage is all the way out before you cut keys.

- 1 Move the depth selector lever to the "0" mark for the setup stroke. You should feel a positive "click" action for each depth-of-cut position.
- 2 Pull down the operating lever completely. **Failure to strike the rubber bumper with the operating lever may make the key carriage move to the next space too soon.**
- 3 Pull the operating lever down firmly until it strikes the rubber bumper. Then, let the operating lever move back up.

The machine automatically moves the key carriage and key blank into place for the first key cut.

Caution: Do not move the key carriage by hand during key cutting; the machine precisely advances the key carriage with each stroke of the operating lever.

- 4 Move the depth selector lever to the depth of cut you need. **Caution:** Let go of the depth selector lever before making a cut. If you put pressure on the depth selector lever while making a cut, the key may be cut wrong.
- 5 Pull the operating lever down firmly until it strikes the rubber bumper. Then, let the operating lever move back up.

The machine makes the first cut and automatically moves the key carriage and key blank into place for the next cut.

- 6 Repeat steps 4 and 5 until you have made all cuts on the key.

3 Unload the key

- 1 Pull the key carriage out.
- 2 Turn the key clamp knob counterclockwise. For left-handed machines, turn the key clamp knob clockwise.
- 3 Slide the key out.