

## Key Combinator Overview

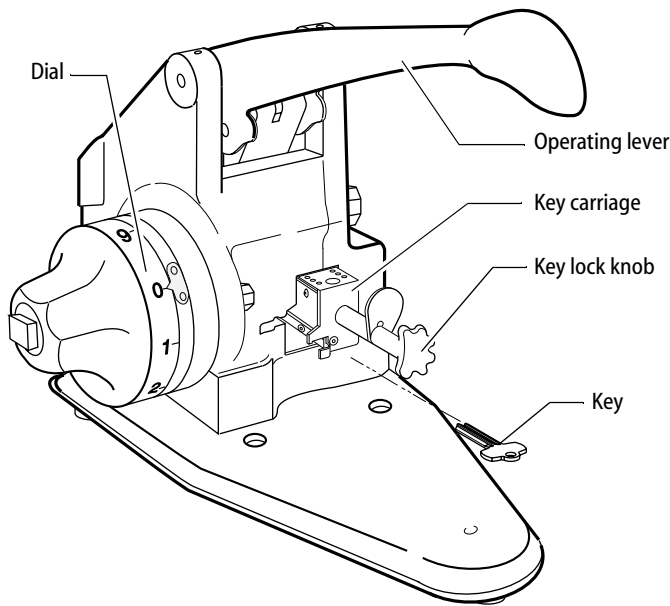

Figure 1 — Key combinator with various parts labeled

### 1 Optional: Adjust the key carriage for large bow keys

Your key combinator is originally set up from the factory to cut standard bow keys, but it can simply be adjusted to allow you to cut large bow keys too. The following figure describes the difference between large and standard bow keys.

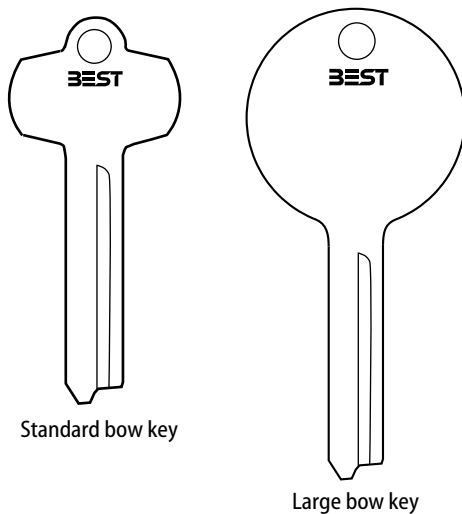

Figure 2 — Standard and large bow keys

#### To set up the key combinator to cut large bow keys:

- 1 From the rear of the key combinator, insert the *key carriage adjusting tool* into the *adjusting knob slots*. See Figure 3.

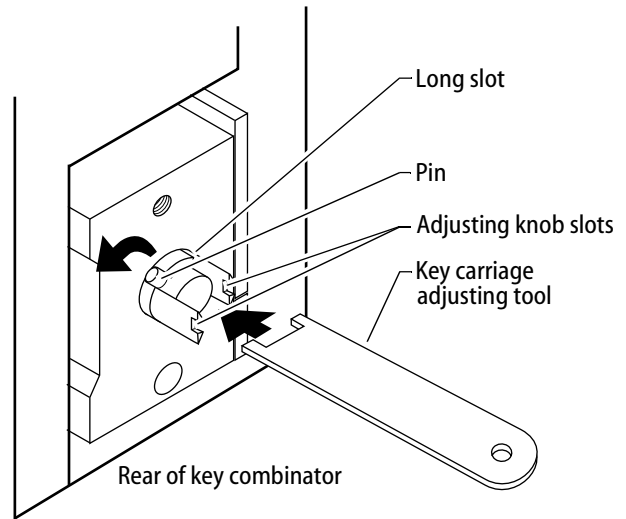

Figure 3 — Changing the key carriage for large and standard bow keys.

- 2 While holding onto the key lock knob, push in on the key carriage adjusting tool and turn counterclockwise until the pin slides into the long slot.
- 3 Release the key carriage adjusting tool.

*The key combinator is now ready to cut large bow keys. Skip to task 2, "Insert the key."*

#### To restore the key combinator to cut standard bow keys:

- 1 From the rear of the key combinator, insert the key carriage adjusting tool into the adjusting knob slots. See Figure 3.
- 2 While holding onto the key lock knob, push in on the key carriage adjusting tool and turn clockwise until the pin slides into the short slot.
- 3 Release the key carriage adjusting tool.

*The key combinator is now ready to cut standard bow keys.*

### 2 Insert the key

- 1 Pull the key carriage out as far as possible. Turn the key lock knob so that the open area will allow the key to be inserted into the key carriage. See Figure 4 and Figure 5.

- 2 Insert the key into the key carriage with the key clamping spring located in the lower keyway slot of the key.

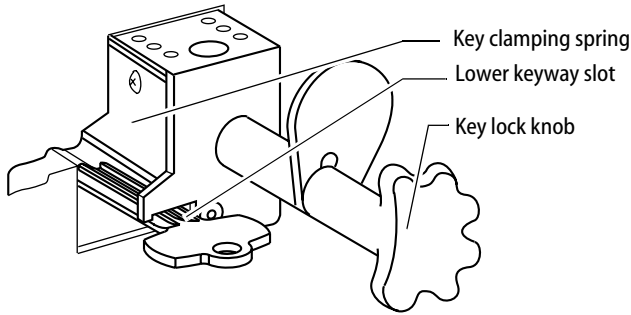

Figure 4 — Inserting the key

**Note 1:** The thicker edge of the key is against the key carriage.

**Note 2:** Avoid any extreme horizontal or vertical pressure on the key which may cause damage to the key clamping spring.

- 3 Push the key forward as far as possible, pull the key lock knob, and turn counterclockwise to clamp the key in the key carriage. See Figure 5.

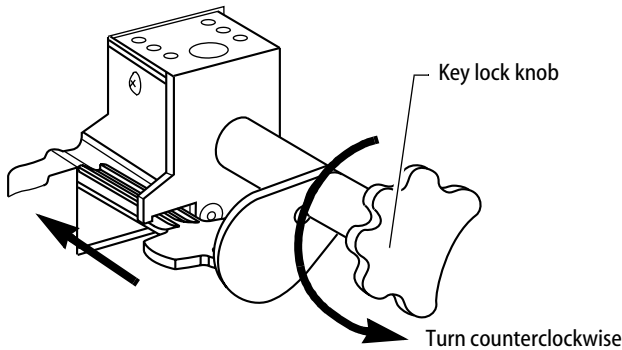

Figure 5 — Clamping the key in place

### 3 Cut the key

- 1 With the key carriage pulled out, set the dial to the zero cut. See figure 1.
- 2 Make a complete downward stroke of the operating lever.
- 3 Release the operating lever to return to the upward position without removing your hand.

*The key is now positioned for the first cut.*

**Caution:** Never allow the operating lever to jump up freely.

- 4 Set the dial for the first cut of the combination. Press down on the operating lever with a firm, swift thrust and make a complete stroke to the extreme downward position.
- 5 Release the operating lever to return to the upward position without removing your hand.

*This action will complete the first cut and index the key carriage so that it's ready for the second cut.*

- 6 Dial the next number of the combination and repeat the above procedure for each cut.

**Note:** The highest number on the dial requires more pressure on the operating lever because it is the deepest key cut. The lower the number, the less pressure required to make the cut.

**Caution:** If you fail to depress the operating lever through a complete stroke, the key will not be cut and will not index the key carriage into position for the next cut.

### 4 Remove the key

- When all cuts are made, pull the key carriage out as far as possible. Turn the key lock knob clockwise to release the key and remove the key, sliding it toward you, avoiding any extreme horizontal or vertical pressure on the key.