



# B.A.S.I.S. Locks Backup Battery Replacement Kit Instructions

## Overview

These instructions describe how to replace the backup battery in your B.A.S.I.S. Mortise Lock (35HG or 35HBV), Cylindrical Lock (93KG–95KG or 93KBV–95KBV), or Exit Hardware Trim (EXG or EXBV).

## Components checklist

In addition to these instructions, this kit (part number 1833843) contains:

- 1 Backup battery
- 2 Outside escutcheon gaskets (one for mortise or cylindrical locks and one for exit hardware trim (EHT))
- 5 Screws (used only for EHT)
- 1 Lift finger screw (used only for EHT)

## Tasks to perform for cylindrical or mortise electronic locks

**Note:** For tasks to perform on EX Series exit hardware trim, see page 2.

### A Remove inside and outside escutcheons from door

For instructions, see the *B.A.S.I.S. G Service Manual* (T63300) or the *B.A.S.I.S. V Service Manual* (T61805).

### B Remove old escutcheon gasket and backup battery

**Caution:** Before you handle the electronics board or any component connected to it, make sure that you are properly grounded using an electrostatic discharge (ESD) protection kit! Touching the board without proper grounding can damage sensitive electronics components—even if you don't notice any static discharge!

- 1 Remove the gasket from the outside escutcheon and discard the gasket.
- 2 Remove the backup battery from the battery socket.

### C Install new backup battery and escutcheon gasket

- 1 Slide the new backup battery under the clip and into position in the battery socket.

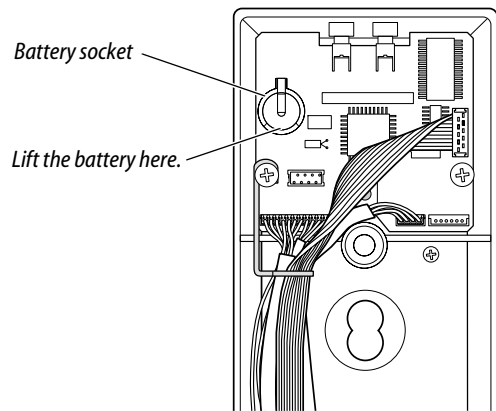

Figure 1 Removing the backup battery

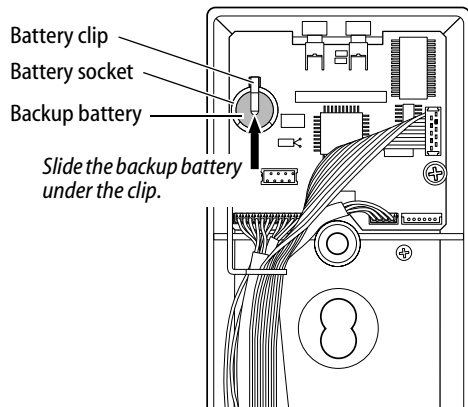

Figure 2 Installing the backup battery

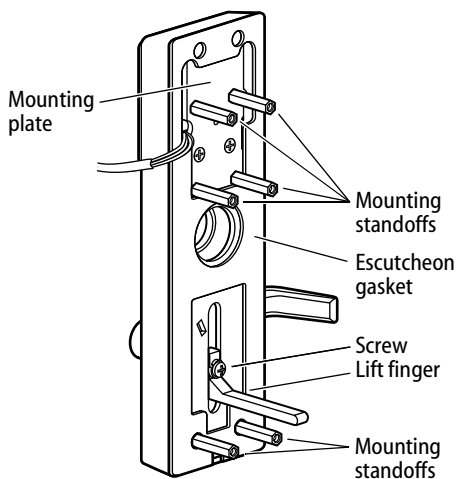

Figure 3 Removing and reinstalling the mounting standoffs, gasket, and lift finger

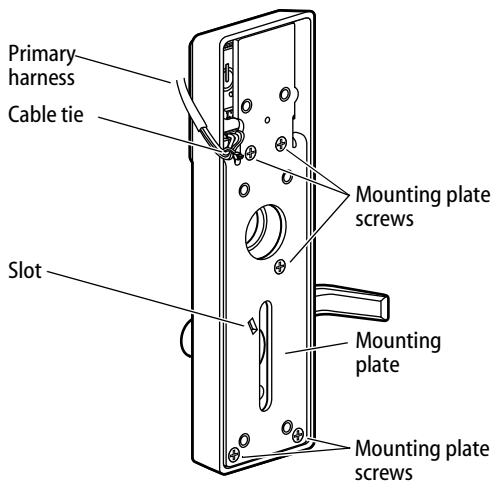

Figure 4 Removing and reinstalling the mounting plate

- 2 Slide the new escutcheon gasket onto the upper escutcheon post. Press the gasket into place on the edge of the escutcheon so the electronics board is covered.

### D Reinstall inside and outside escutcheons on door

For instructions, see the *B.A.S.I.S. G Service Manual* or the *B.A.S.I.S. V Service Manual*.

**Note:** Skip to page 4, Test lock for proper operation.

## Tasks to perform for EX Series Exit Hardware Trim

### A Remove the escutcheon from door

For instructions, see the *B.A.S.I.S. G Service Manual* (T63300) or the *B.A.S.I.S. V Service Manual* (T61805).

### B Remove old escutcheon gasket and backup battery

**Caution:** Before you handle the electronics board or any component connected to it, make sure that you are properly grounded using an electrostatic discharge (ESD) protection kit! Touching the board without proper grounding can damage sensitive electronics components—even if you don't notice any static discharge!

- 1 Unscrew the six mounting plate standoffs from the mounting plate (Figure 3).
- 2 Remove the gasket from the escutcheon and discard the gasket.
- 3 Remove the lift finger:
  - a Note the orientation of the lift finger.
  - b Remove the lift finger screw and discard.
  - c Remove the washer and lift finger.
- 4 Remove the mounting plate (Figure 4):
  - a Cut the cable tie and discard.
  - b Remove the five screws and discard.
  - c Carefully remove the mounting plate.
- 5 Remove the backup battery from the battery socket (Figure 1).

**C Install new backup battery and escutcheon gasket**

- 1 Slide the new backup battery under the clip and into position in the battery socket (Figure 5).
- 2 Slide the new escutcheon gasket onto the upper escutcheon post. Press the gasket into place on the edge of the escutcheon so the electronics board is covered.
- 3 With posts on the mounting plate inserted in the lever return springs, slide the mounting plate into the escutcheon (Figure 6). Make sure that the locking plate fits into the slot in the mounting plate. Secure with the five new screws. Route the primary harness against the mounting plate post and secure the harness to the post with a cable tie. See Figure 4.
- 4 Position the lift finger on the escutcheon in the orientation noted in step 3a on page 2.
- 5 Position the washer on the lift finger screw. Tightly secure the lift finger with the lift finger screw (25–30 foot-pounds of torque) (Figure 3).
- 6 Starting at the bottom of the gasket, peel away the protective backing a small amount at a time while unrolling the gasket into position on the escutcheon. Press the gasket into place.
- 7 Screw the six mounting standoffs onto the mounting plate (Figure 3).

**D Reinstall the escutcheon on door**

For instructions, see the *B.A.S.I.S. G Service Manual* or the *B.A.S.I.S. V Service Manual*.

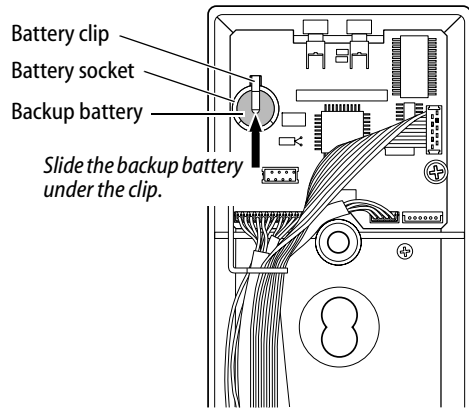

*Figure 5 Installing the backup battery*

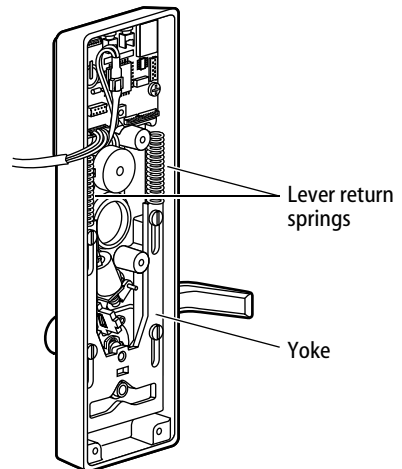

*Figure 6 Removing and reinstalling lever return springs*

## **Tasks to perform for all B.A.S.I.S. locks and EX Series Exit Hardware Trim**

### **E Test lock for proper operation**

To test the lock for proper operation before the lock is programmed, use the temporary operator card that came with the lock. This card is for temporary use only. After permanent cards have been programmed for the lock, the temporary card should be deleted.

- 1 Use the temporary operator card to activate the lock.

When the lock detects the presence of a card for the first time, the lock performs a series of diagnostic self-tests. If no problem is detected, the lock responds with 4 red LED flashes, simultaneous with 4 green LED flashes and 4 short tones.

If a problem is detected, the lock's red LED and green LED simultaneously flash in a repeating pattern (and no tones sound). The lock's control electronics board must be replaced. For instructions, see the *B.A.S.I.S. G Service Manual* or the *B.A.S.I.S. V Service Manual*.

**Note:** *If the lock has a proximity card reader, it may have already been activated by the presence of an object near the card reader.*

- 2 Use the temporary operator card to access the lock.  
The green light flashes and the locking mechanism unlocks.
- 3 Turn the lever and open the door.

**If the mechanism doesn't unlock, refer to the following table.** For additional troubleshooting instructions, see the *B.A.S.I.S. G Service Manual* or the *B.A.S.I.S. V Service Manual*.

<b>LEDs</b>	<b>Sounder</b>	<b>You should</b>
Single red flash	—	Use the card at a moderate speed.
Red flashes	3 short tones	Use the temporary operator card provided with the lock.
Green flashes	—	Check the motor connection.
—	—	Check the battery connection.

### **For locks with key override**

Insert and turn the key to unlatch the door.

### **For locks with deadbolt**

From the inside of the door, turn the turn knob and make sure that the deadbolt operates properly.