



Installation Instructions for 34HW–35HW IDH Max Mortise Locks

Overview

The 34HW–35HW IDH Max Mortise Lock provides the following features in an integrated lock, eliminating the need to install separate sensors in and around the door frame:

- electrified locking mechanism
- electronic token reader
- integrated trim
- door status detection
- latchbolt status detection
- ability to exit without triggering an alarm
- compatibility with varied access control panels/reader interfaces.

Note: For a list of compatible access control panels/reader interfaces, contact your local BEST representative.

A panel interface module is provided with the lock. The panel interface module receives token data and lock sensor data from the lock through an RS-485 connection. It translates this data into parallel signals, which it sends to the access control panel/reader interface. The panel interface module also translates control signals received from the access control panel/reader interface and sends them to the lock. The figure below shows the relationship between the components in the IDH Max system.

Contents

These installation instructions describe how to install, wire, and configure the components provided with your 34HW–35HW IDH Max Mortise Lock. The following topics are covered.

Site survey 2

Components checklist 2

Special tools checklist 3

Preparing the door and door jamb 4

Installing the lock 8

Completing the installation at the door 13

Installing the panel interface module 18

Testing the installation 23

Troubleshooting the installation 24

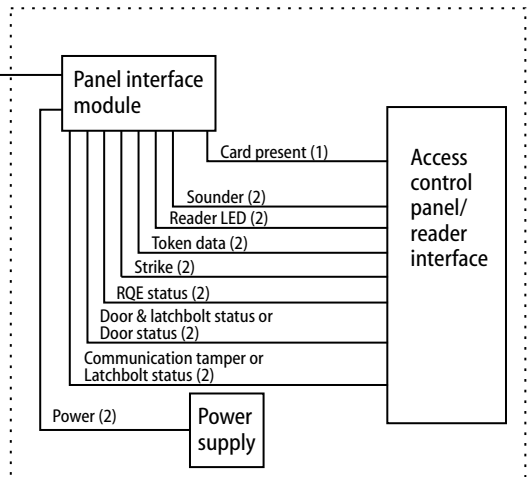
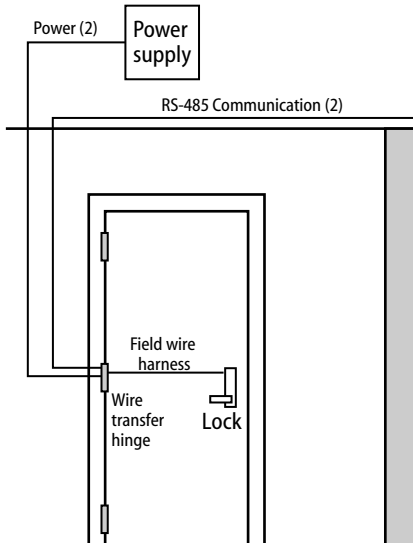

Site survey

Use the following survey to record information about the installation site. You need this information to determine field wiring needs, select a power supply, and determine how to prepare the door for the lock.

Lock information

Lock function:

- EEL—Electrically locked with key
- EEU—Electrically unlocked with key
- NEL—Electrically locked without key
- NEU—Electrically unlocked without key

Power source for lock:

- Separate power supply
- Power provided through panel interface module

Power source for panel interface module:

- Separate power supply
- Power provided through access control panel

Distance of lock site from lock power source: _____ feet

Distance of lock site from panel interface module site: _____ feet

Door information

Door handing and bevel:

- Left hand (LH)
- Left hand, reverse bevel (LHRB)
- Right hand (RH)
- Right hand, reverse bevel (RHRB)

Door thickness: _____ inches (1 3/4" – 3")

Environment information

Ambient temperature:

- Is within specifications. See the tables below.

This product meets the following Locked Door Outdoor test requirements for ANSI/BHMA 156.25:

Side of door	Range
Inside	+66°F to +74°F (+19°C to +23°C)
Outside	–31°F to +151°F (–35°C to +66°C)

This product meets the following Full Indoor test requirements for ANSI/BHMA 156.25:

Side of door	Range
Inside and outside	+32°F to +120°F (0°C to +49°C)

Components checklist

Use the following checklist to make sure that you have the items necessary to install the components provided with your 34HW–35HW IDH Max Mortise Lock.

Components provided in the box:

- Mortise case assembly
- Mortise case faceplate
- Inside escutcheon assembly with field wire harness
- Inside escutcheon access door
- Outside escutcheon assembly
- Inside and outside mounting plates
- Inside knob/lever
- Outside knob/lever & spindle assembly
- Cylinder assembly (for use with EEL and EEU functions only)
- Mortise screw package
- Trim hole insert package
- Plastic bushing package
- Escutcheon screw package
- Panel interface module
- Strike
- Strike box with magnet
- Spacer (for 6-pin cores)
- Bar code ID sticker (for your records)

Other items you'll need:

- Power supply for one IDH Max Mortise Lock (if you're providing a separate power supply): regulated; 12 volts DC at 1.1 amps

Note: *If you intend to power more than one lock with the same power supply, calculate the amperage for the power supply by multiplying 1.1 by the number of IDH Max Mortise Locks (.85 by the number of IDH Max Cylindrical locks).*

- Power supply for the panel interface module (if you're providing a separate power supply): 12 volts DC at .1 amp
- Wire transfer hinge: 8 conductors min.; 28 AWG min.

continued

Components checklist

- Field wiring for power connections between the lock and power supply or the lock and panel interface module.

If you're powering the lock(s) through the panel interface module, calculate the total length of the power wire run by summing:

- The distance from the power supply to the panel interface module.
- The distance from the panel interface module to the first door.
- If powering more than one door daisy-chained to the same power supply, add the total distance of the power runs between the doors.

If you're powering the lock(s) using a separate power supply, calculate the total length of the power wire run by summing:

- The distance from the power supply to the first door.
- If powering more than one door daisy-chained to the same power supply, add the total distance of the power runs between the doors.

Refer to the table below to determine the minimum wire gauge based on the number of doors sharing the power supply and the total length of the wire run.

Maximum wire length based on				
no. of doors	daisy-chained to power supply			Minimum wire gauge
1 door	2 doors	3 doors	4 doors	
250 feet	125 feet	75 feet	60 feet	18 AWG
400 feet	200 feet	130 feet	100 feet	16 AWG
600 feet	300 feet	185 feet	150 feet	14 AWG

- Field wiring for RS-485 communication connections between the lock and panel interface module (4000 feet maximum):
Category 5, shielded twisted pair; 24 AWG min.

Special tools checklist

Use the following checklist to make sure that you have the special tools necessary to install the components provided with your 34HW–35HW IDH Max Mortise Lock.

- Three (3) to four (4) foot, 3/8" drill bit
- T15 TORX® bit driver[‡]

[‡] TORX is a registered trademark of the Camcar Division of Textron.

Preparing the door and door jamb

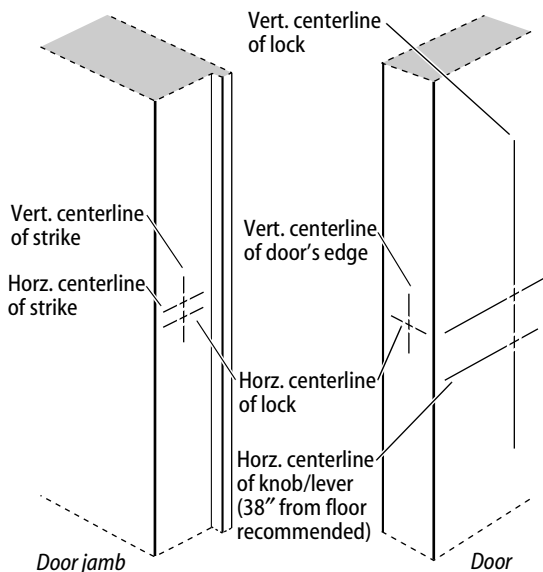

Figure 1 Marking the centerlines

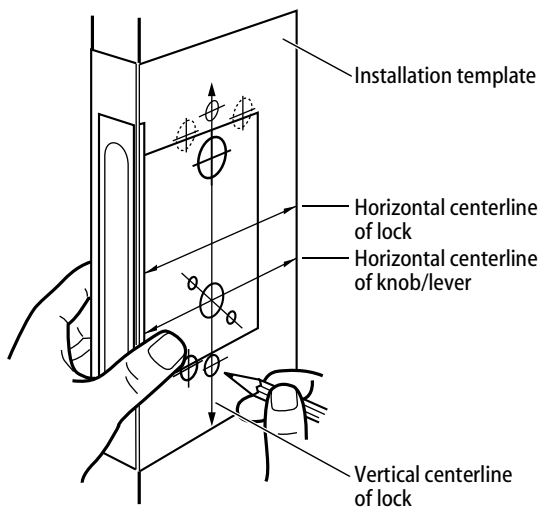

Figure 2 Positioning the template

1 Mark centerlines

Note: If the door is a fabricated hollow metal door, determine whether it is properly reinforced to support the lock. If door reinforcement is not adequate, consult the door manufacturer for information on proper reinforcement. For dimensions for preparing metal doors, see the W13 Template—Installation Specifications for 34HW–35HW IDH Max Mortise Locks.

- 1 On the door, measure and mark the height of the centerline of the knob/lever from the floor (38" recommended). On both sides of the door, on the door's edge, and on the door jamb, mark the horizontal centerline of the lock 1 1/2" above the centerline of the knob/lever.

Note: If the door is a LH or RH door, mark the inside of the door. If the door is a LHRB or RHRB door, mark the outside of the door.

- 2 On the door's edge and door jamb, mark the vertical centerline of the lock.
- 3 Measure and mark the backset (2 3/4" standard) from the vertical centerline on the door's edge. On both sides of the door, mark the vertical centerline of the lock.
- 4 On the door jamb, mark the horizontal centerline of the strike 3/8" above the horizontal centerline of the lock.

2 Position template and mark drill points

- 1 Cut the W15 Template—Installation Template for 34HW–35HW IDH Max Mortise Locks along the dashed lines and align the horizontal and vertical arrows with the marked centerlines on the door.
- 2 Tape the template to the door.
- 3 Center punch the necessary drill points. Refer to the instructions on the template.

Preparing the door and door jamb

3 Mortise for lock case and faceplate

- 1 Mortise the edge of the door for the lock case.

Note: The mortise cavity depth of 4 5/8" includes clearance for wiring behind the mortise case.

- 2 Insert the lock in the mortise cavity.
- 3 Mark the outline of the lock faceplate.
- 4 Remove the lock. Mortise to fit the faceplate.

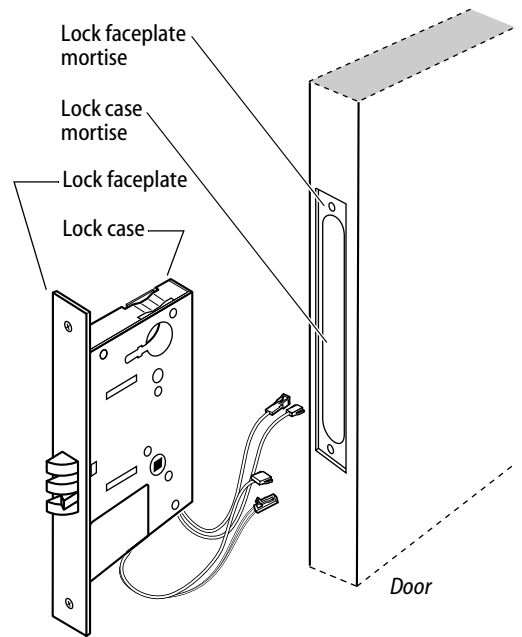

Figure 3 Mortising for the lock case and faceplate

Preparing the door and door jamb

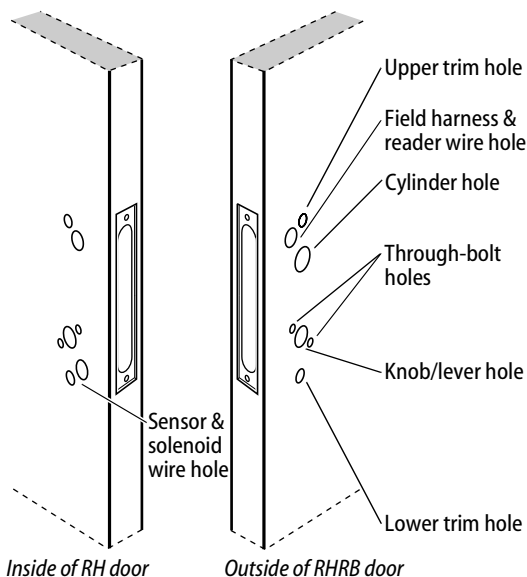

Figure 4a Drilling the RH and RHRB holes

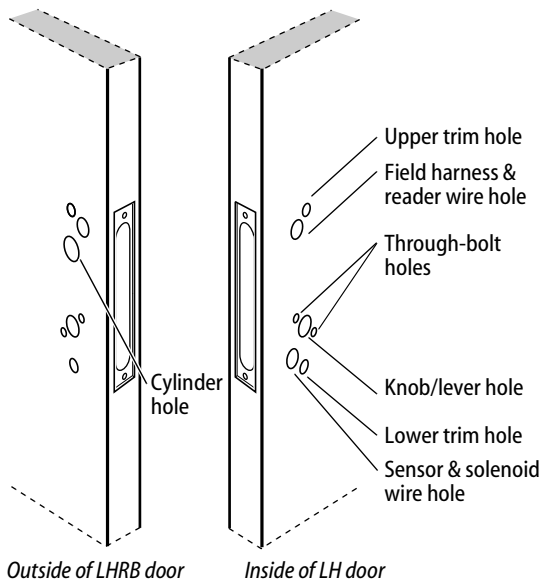

Figure 4b Drilling the LH and LHRB holes

4 Drill holes

Caution: Check for the correct lock function, hand, and bevel before drilling.

Drill the holes listed below:

- upper and lower trim holes
 - 5/8" diameter
 - through door
- field harness & reader wire hole
 - 7/8" diameter
 - through door
 - location based on handing
- cylinder hole
 - 1 1/4" diameter
 - from outside into mortise cavity
 - EEL and EEU functions only
- upper and lower through-bolt holes
 - 3/8" diameter
 - through door
- knob/lever hole
 - 7/8" diameter
 - through door
- sensor & solenoid wire hole
 - 7/8" diameter
 - from inside into mortise cavity, approximately 1" deep

Note 1: To locate the center of a hole on the opposite side of the door, drill a pilot hole completely through the door.

Note 2: For holes through the door, it is best to drill halfway from each side of the door to prevent the door from splintering.

Preparing the door and door jamb

5 Drill hole for field wire harness

Caution 1: Check with your local fire marshal before drilling a fire-rated door. Drilling through a fire-rated door may void the fire label.

Caution 2: Be careful to drill straight through the door, making sure the drill does not break through the face of the door.

- 1 Remove the hinge nearest to the mortise cavity.
- 2 Using a three (3) to four (4) foot drill bit, drill a 3/8" diameter hole through the upper back of the mortise cavity to the center of the nearest hinge mortise.

Note: It may be easier to drill halfway from each side of the door.

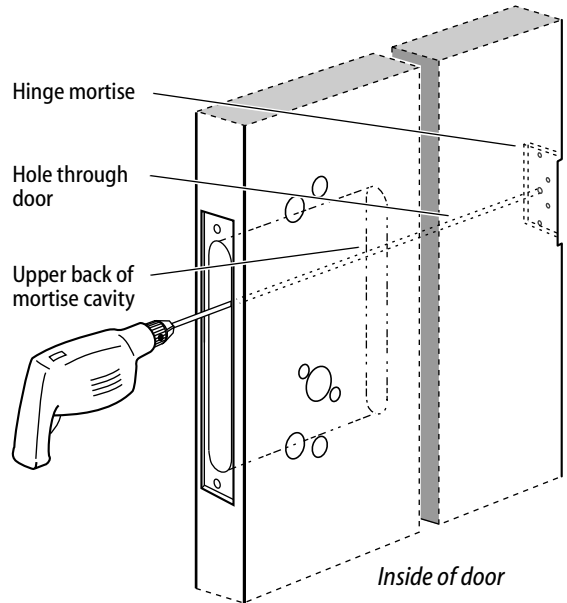

Figure 5 Drilling the hole for the field wire harness

6 Prepare for wire transfer hinge and run field wiring

- 1 Drill a wire access hole through the frame side of the hinge mortise.
- 2 Drill holes (or pockets) for splice connectors in the frame and door. Refer to the hinge manufacturer's specifications for the hole location.
- 3 De-burr the holes to prevent damage to the hinge leads.
- 4 Run the power field wiring from the location for the lock's power supply to the location for the wire transfer hinge.
- 5 Run the communication field wiring from the location for the panel interface module to the location for the wire transfer hinge.

Note: For an overview of the system, see the figure on page 1. For specifications for power and communication field wiring, see Components checklist, on page 2.

- 6 Pull the field wiring down the wall and through the access hole in the frame.

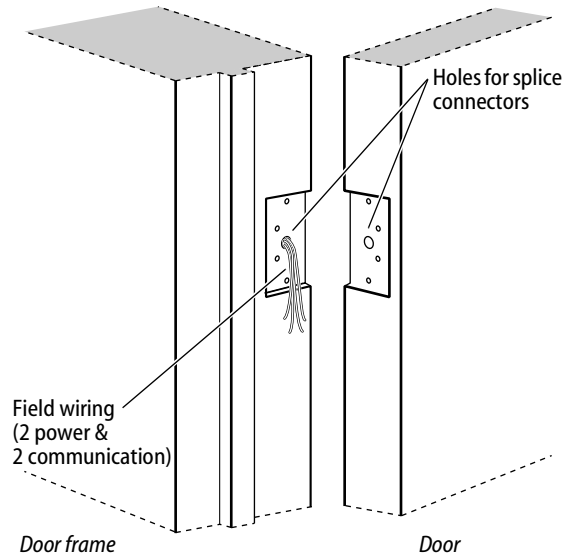
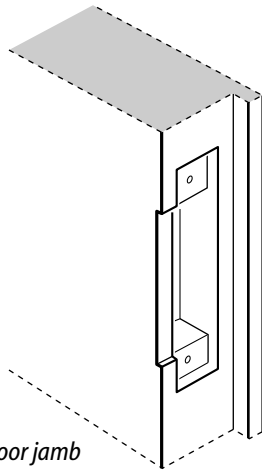

Figure 6 Preparing for the wire transfer hinge

Installing the lock



Door jamb

Figure 7 Mortising the door jamb for the strike box and strike plate

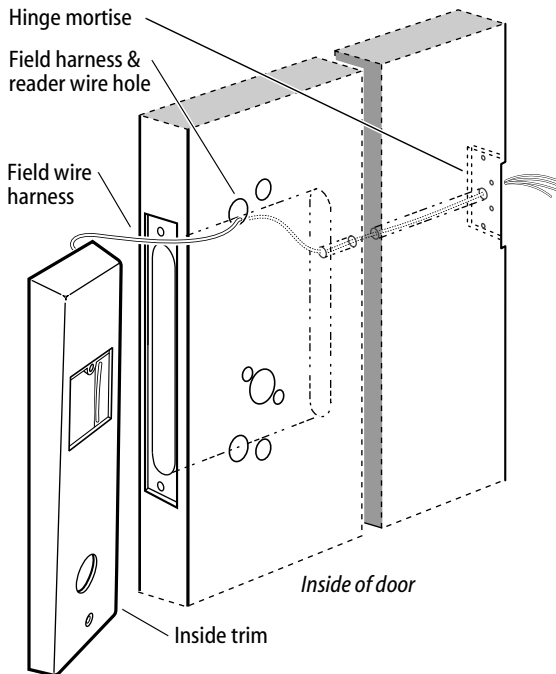

Figure 8 Pulling the field wire harness through the door

7 Mortise for strike box and strike plate

- 1 On the door jamb, locate the horizontal centerline of the strike ($3/8''$ above the centerline of the lock), as well as the vertical centerline of the strike.
- 2 Mortise the door jamb to fit the strike box and strike plate.

8 Pull field wire harness through door

- 1 Feed the field wire harness (connected to the inside trim) into the field harness & reader wire hole and down into the mortise cavity.
- 2 From the hinge edge of the door, fish the field wire harness through the door to the hinge mortise.

Note: You can let the inside trim dangle from the field wire harness while completing tasks 9 through 13.

Installing the lock

9 Install mortise case

- 1 Remove the faceplate from the mortise case.
- 2 Insert the mortise case into the mortise cavity, while feeding the sensor and solenoid wires into the mortise cavity and out the sensor & solenoid wire hole to the inside of the door.

Note: The field wire harness should be routed above and behind the mortise case (depending on where the hole through the door meets the mortise cavity).

- 3 Make sure there are 3" to 4" of slack in the field wire harness to allow access to the control electronics circuit board in the inside trim.
- 4 Secure the mortise case with the case mounting screws.

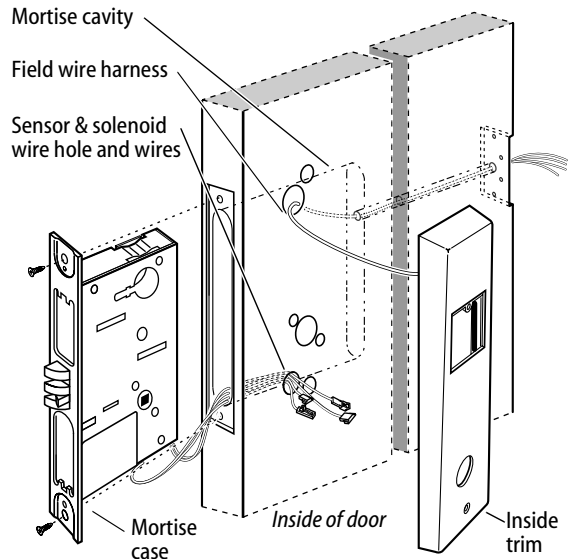

Figure 9 Installing the mortise case

10 Install mounting plates

- 1 Insert the outside mounting plate through the door and mortise case.
- 2 Position the inside mounting plate opposite the outside mounting plate and screw them securely in place.

Caution: Do not overtighten the mounting plate screws. Overtightening may compress the mortise cavity and bind the locking mechanism.

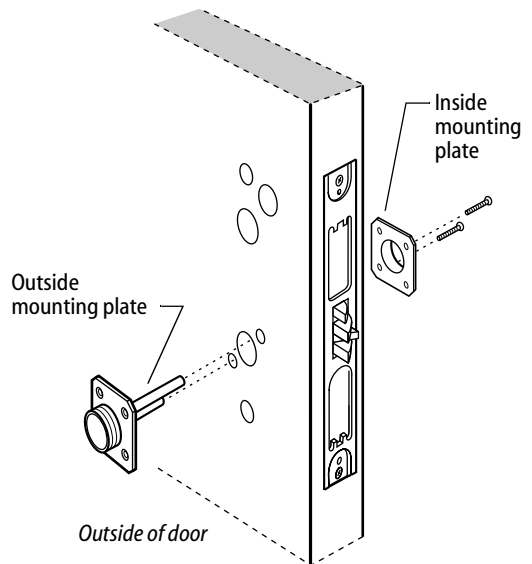

Figure 10 Installing the mounting plates

Installing the lock

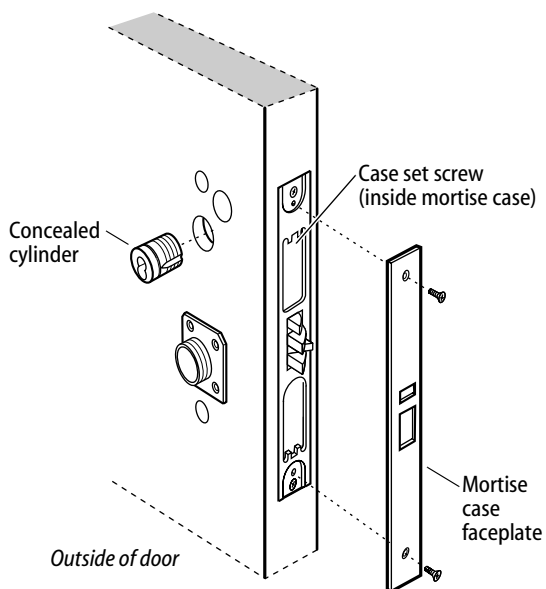

Figure 11 Installing the cylinder and mortise case faceplate

11 Install cylinder and mortise case faceplate

Note: Install the cylinder for EEL and EEU function locks only.

- 1 Thread the concealed cylinder into the mortise case so that the groove around the cylinder head is even with the door surface. Adjust the cylinder depth plus or minus one (1) turn so that the core, when installed in the cylinder, is flush with the outer surface of the trim.

Caution: A malfunction can occur if the cylinder is threaded in too far.

- 2 Secure the cylinder in the mortise case with the case set screw.
- 3 Secure the mortise case faceplate to the mortise case with the faceplate mounting screws.
- 4 Check the cylinder and lock for proper operation.

Installing the lock

12 Install trim hole inserts and bushings

- 1 Insert the two trim hole inserts into the upper trim hole on each side of the door, as shown in Figure 12.
- 2 Insert two bushings into the field harness & reader wire hole on each side of the door, as shown in Figure 12.
- 3 Insert a bushing into the sensor & solenoid wire hole on the inside of the door, as shown in Figure 12.

Note: You do **not** need to change the positions of the DIP switches on the control electronics circuit board located in the inside escutcheon.

- By default, switches 1 through 5 are set to ON. These switches are for possible future applications.
- By default, switches 6 and 7 are set to ON for automatic baud rate detection. This setting lets you determine the baud rate for communication between the lock's control electronics circuit board and the panel interface module by setting DIP switches on the panel interface circuit board. (See page 21.)
- Switch 8 is set to OFF for locks with a swipe-type magnetic stripe card reader, a proximity reader, or a keypad reader; it is set to ON only for locks with an insertion-type magnetic stripe card reader.

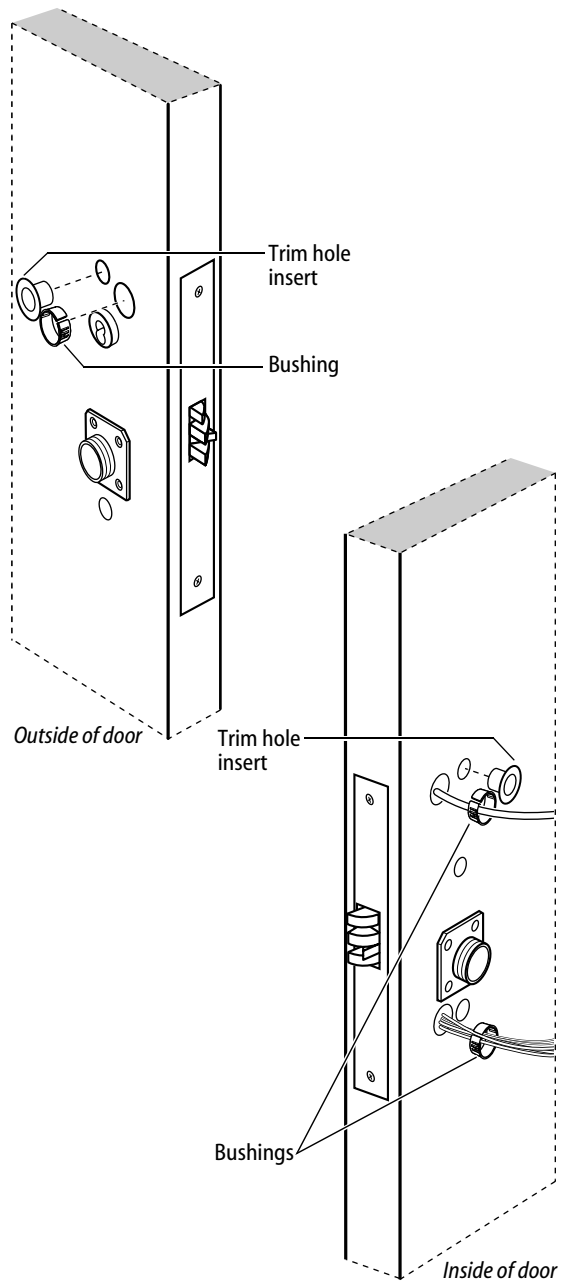

Figure 12 Installing the trim hole inserts and bushings

Installing the lock

13 Connect reader wire harness

1 From the outside of the door, feed the reader wire harness connector through the field harness & reader wire hole.

2 Temporarily rest the outside trim on the door by inserting the trim studs into the stud holes.

Note: You can temporarily install the outside knob/lever to hold the outside trim in place. See Task 15.

3 Connect the reader wire harness to the control electronics circuit board in the inside trim.

4 Feed the solenoid and sensor wire harness from the control electronics circuit board, as well as the solenoid and sensor wires from the mortise case, through the large opening in the inside trim.

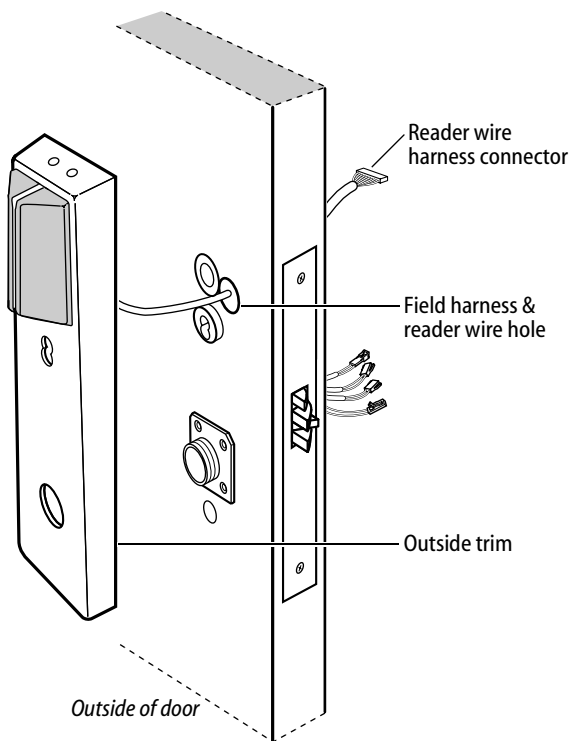

Figure 13a Feeding the reader wire harness connector from the outside trim through the door

Caution 1: When routing the reader wire harness, make sure the reader wire harness is not routed across any sharp edges or over any surface that could damage its sleeving or wire insulation.

Caution 2: When connecting the reader wire harness, make sure:

- there are no loose wire connections where the wires are inserted into the reader wire connector
- the reader wire harness connector is fully seated in its mating connector on the control electronics circuit board.

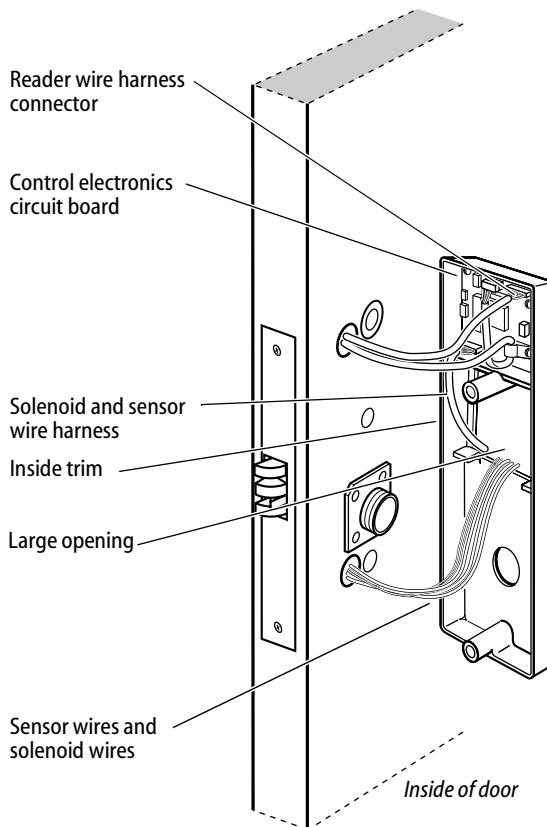

Figure 13b Connecting the reader wire harness to the control electronics circuit board

Completing the installation at the door

14 Secure through-bolt trim and complete connections

- 1 Position the inside and outside trim onto the door.
- 2 **Making sure that the trim does not pinch the wires**, secure the trim to the door—but do not tighten. Use the combination mounting screw at the top trim hole and the standard mounting screw at the bottom trim hole.

Caution: When routing the solenoid and sensor wire harness, the sensor wires, and the solenoid wires, make sure the wires are not routed across any sharp edges or over any surface that could damage their sleeving or wire insulation.

- 3 Make the solenoid connection and three sensor connections, and place the wires into the inside trim.

Wire connection	Color	No. of wires	No. of pins
Solenoid	Yellow	2	3
RQE	Brn/Org	2	3
Shorting connection	Purple	2	2
Door status sensor	White	2	2

Caution: When making the sensor connections and solenoid connection, make sure:

- there are no loose wire connections where the wires are inserted into the connectors
- the connectors are firmly mated.

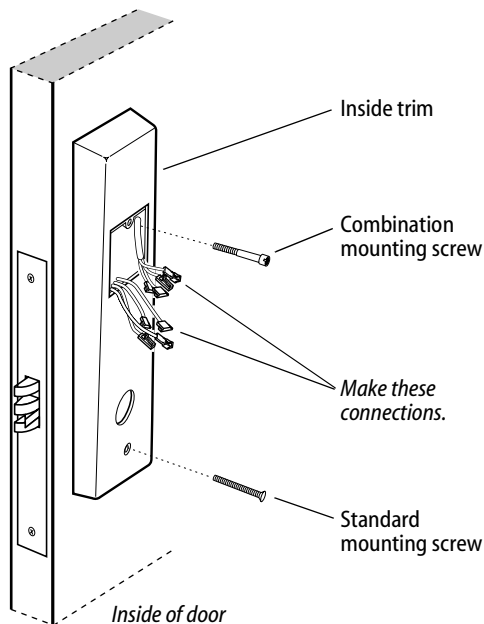

Figure 14 Securing the through-bolt trim and completing connections

Completing the installation at the door

15 Install inside and outside knobs/levers

For both knobs and levers

Unscrew the inside spindle one (1) full turn to allow the spindles to turn freely.

For knobs

- 1 From the outside of the door, insert the outside knob and spindles assembly into the lockset.
- 2 Slide the inside knob onto the inside spindle and secure it with the set screw.
- 3 Push the set screw cap into the set screw hole.
- 4 Tighten the trim mounting screws.
- 5 Turn the knobs to check that they operate smoothly.

For levers

- 1 With the handle pointing toward the door hinges, insert the outside lever and spindles assembly into the lock from the outside of the door.
- 2 Slide the inside lever onto the inside spindle and secure it with the set screw.
- 3 Tighten the trim mounting screws.
- 4 Turn the levers to check that they operate smoothly.

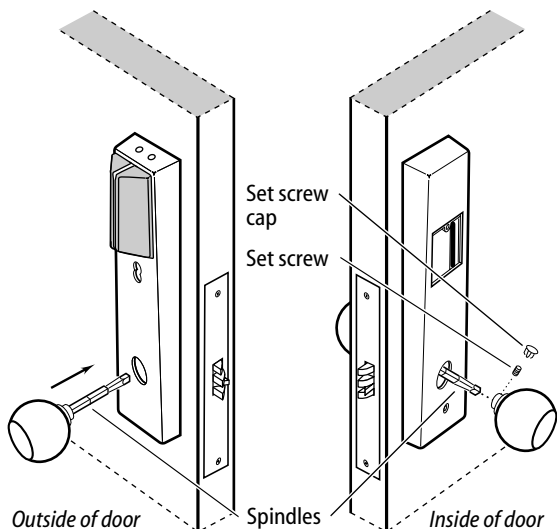

Figure 15a Installing the knobs

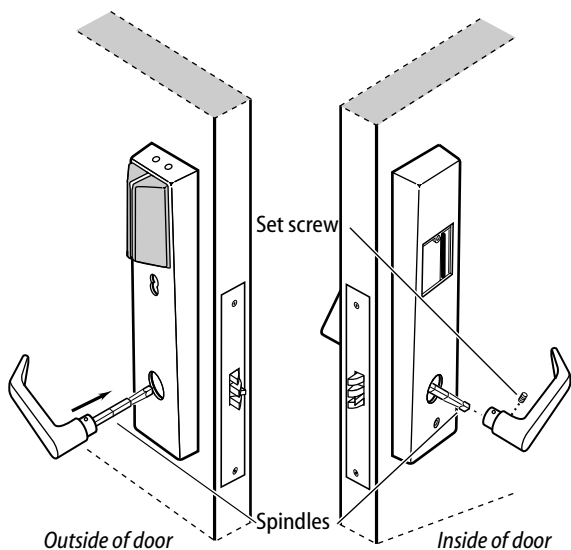

Figure 15b Installing the levers

Completing the installation at the door

16 Install core (EEL and EEU only)

- 1 Insert the control key into the core and rotate the key 15 degrees to the right.
- 2 With the control key in the core, insert the core into the cylinder.
- 3 Rotate the control key 15 degrees to the left and withdraw the key.

Caution: The control key can be used to remove cores and to access doors. Provide adequate security for the control key.

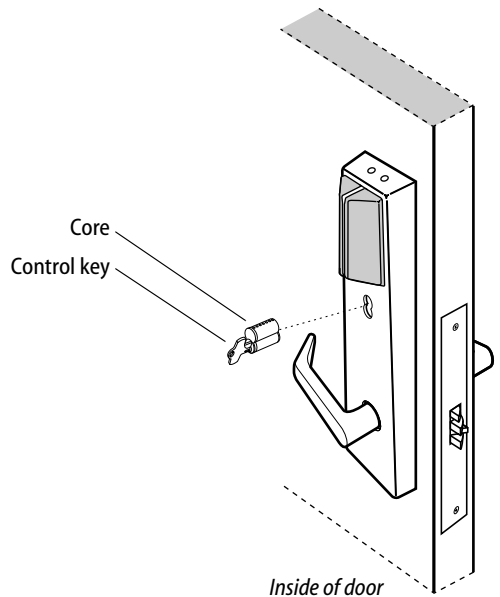

Figure 16 Installing the core

17 Install access door

- 1 **Making sure that the access door does not pinch any wires**, insert the tabs of the access door into its mating slots and swing the door closed.
- 2 Use a T15 TORX bit driver to secure the access door with the security screw. Tighten firmly.

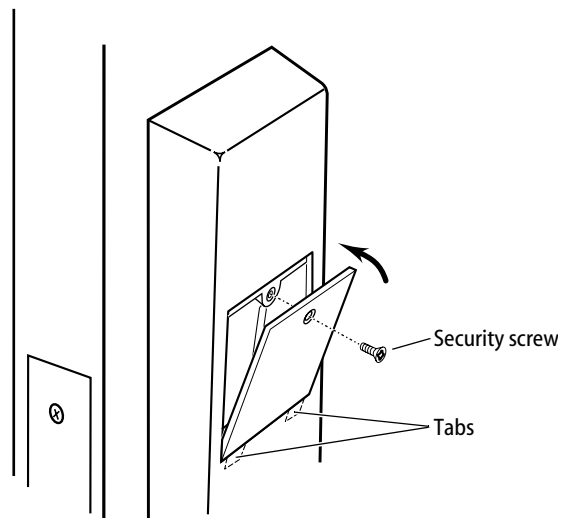

Figure 17 Installing the access door

Completing the installation at the door

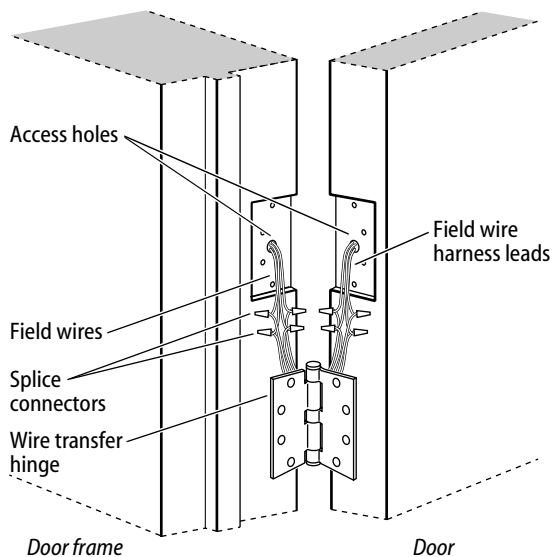

Figure 18 Installing the wire transfer hinge

18 Install wire transfer hinge

- 1 Trim the four wires of the field wire harness, which you pulled through the hinge edge of the door in Task 8. Leave sufficient length to connect to the wire transfer hinge.
- 2 Splice the power and communication field wiring to the four pairs of leads on the frame side of the hinge, following the hinge manufacturer's instructions.
- 3 Splice the four field wire harness wires (listed in the table below) to the four pairs of leads on the door side of the hinge, matching each pair of leads to its corresponding field wire.

Wire	Color
Ground	Black
12 VDC	Red
Com+	Orange
Com–	Green

- 4 Insert the wires and splice connectors into the holes or pockets in the door and frame, being careful not to pinch the wires. Install the wire transfer hinge.

Completing the installation at the door

19 Install strike box and strike plate

- 1 Insert the strike box into the mortise in the door jamb. Place the strike plate over the strike box and secure the strike with the screws provided.
- 2 Check the position of the auxiliary bolt against the strike plate.

Caution: The auxiliary bolt must make contact with the strike plate. The auxiliary bolt deadlocks the latchbolt and prevents someone from forcing the latch open when the door is closed. If the incorrect strike is installed, a lock-in can occur.

Note: The recommended gap between the door and jamb is 1/8".

20 Install lock power supply (optional)

If you are providing a separate power supply for the lock, instead of providing power via the panel interface module, connect the two power field wires (run from the wire transfer hinge) to the power supply. Make sure power (12 volts DC) and ground are connected properly.

Follow the instructions provided by the power supply manufacturer. Do not plug in the power supply yet.

Note: For specifications for the power supply, see Components checklist, on page 2.

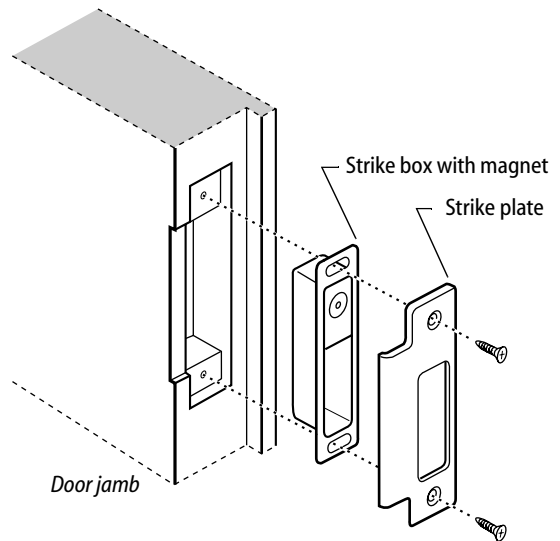

Figure 19a Installing the strike box and strike plate

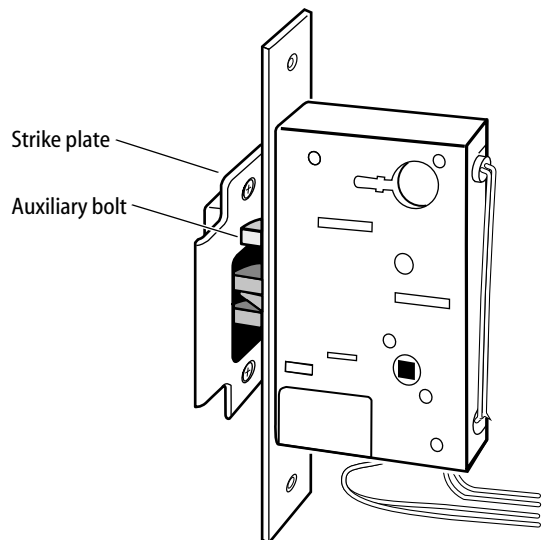

Figure 19b Positioning the strike

Installing the panel interface module

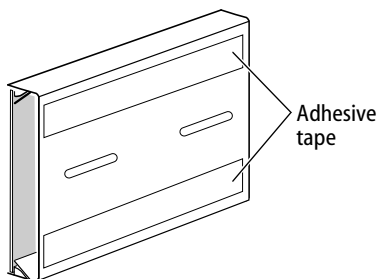

Figure 20 Mounting the panel interface module

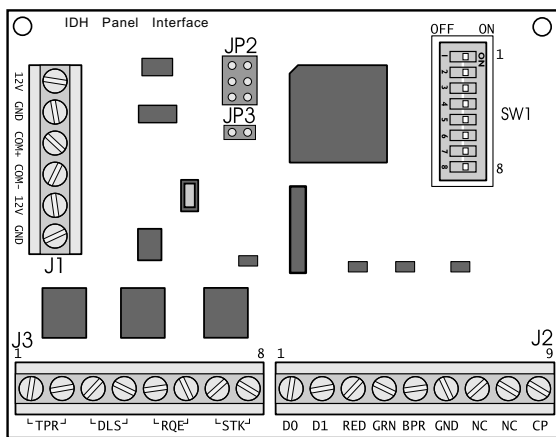

Figure 21a Panel interface circuit board

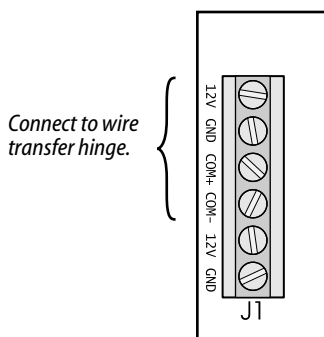

Figure 21b Connecting field wiring from the wire transfer hinge

21 Mount panel interface module

Peel the paper off the adhesive tape affixed to the back of the panel rail and press the panel rail into position.

Note: Mount the panel interface module in the enclosure with the access control panel/reader interface, if possible.

22 Connect field wiring from wire transfer hinge to panel interface module

- 1 Connect the two communication field wires (run from the wire transfer hinge) to the COM+ and COM– terminals on the panel interface circuit board.

Note: The field wire harness leads, connected to the door side of the wire transfer hinge, are described in the table below.

Wire	Color
Ground	Black
12 VDC	Red
Com+	Orange
Com–	Green

- 2 If you are providing power to the lock through the panel interface module, connect the two power field wires (run from the wire transfer hinge) to the 12V and GND terminals on the panel interface circuit board.

Note: JP2 and JP3, shown in Figure 21a, are used for manufacturing purposes only.

- 3 Connect the RS-485 shield wire to one of the GND terminals on J1.

Installing the panel interface module

23 Connect panel interface module to access control panel/reader interface

With power removed from the panel interface circuit board and the access control panel/reader interface, connect the wiring between the panel interface circuit board and the access control panel. Refer to the table below.

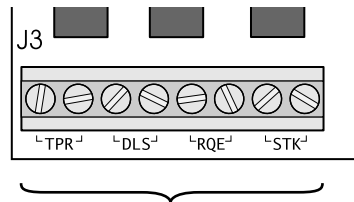

Figure 22a Connecting to the access control panel/reader interface

Connecting to the access control panel/reader interface

Terminals	Description	Related DIP switches
TPR (on J3) Communication tamper output <i>or</i> Latchbolt status output	Switch-like output to the access control panel/reader interface that is configured using DIP switch 8 to serve one of two possible functions: Option 1—Communication tamper output: Indicates the status of the communication connection between the panel interface circuit board and the lock's control electronics circuit board. By default, the output is closed to indicate communication is OK and open to indicate communication has been interrupted. Option 2—Latchbolt status output: Indicates the state of the lock's latchbolt status switch. By default, the output is closed to indicate the latchbolt status switch is closed. Note: <i>The lock's latchbolt status switch is closed when the latchbolt is extended.</i>	DIP switch 8 configures the function of this output. DIP switch 6 provides the ability to invert the signal.
DLS (on J3) Door status & latchbolt status output <i>or</i> Door status output	Switch-like output to the access control panel/reader interface that is configured using DIP switch 8 to serve one of two possible functions: Option 1—Door status & latchbolt status output: Indicates whether the door is secure (both the door status and latchbolt status switches are closed) or unsecure (one or both of these switches are open). By default, the output is closed to indicate the door is secure. Option 2—Door status output: Indicates the state of the lock's door status switch. By default, the output is closed to indicate the door status switch is closed. Note: <i>The lock's door status switch is closed when the door is closed.</i>	DIP switch 8 configures the function of this output. DIP switch 5 provides the ability to invert the signal.
RQE (on J3) Request-to-exit status output	Switch-like output to the access control panel/reader interface that indicates the status of the lock's RQE switch. By default, the output is closed to indicate the RQE switch is closed. Note: <i>The lock's RQE switch is closed when the door knob/lever is turned, activating the switch.</i>	DIP switch 4 provides the ability to invert the signal.
STK (on J3) Strike input	Input from the access control panel's/reader interface's strike relay, which provides the solenoid control signal. The access control panel/reader interface output usually has normally open (NO) and normally closed (NC) terminals, as well as a common terminal. The common and NO terminals should be connected to the two STK terminals on J3. To invert the operation, use the access control panel's/reader interface's common and NC terminals. The operation of the solenoid varies by lock function. See the <i>W Series Service Manual</i> (T60775).	None

continued

Installing the panel interface module

Terminals	Description	Related DIP switches								
D0, D1, & CP (on J2) Token data output	D0 is the Data 0 (Wiegand) or Strobe (ABA) token data output to the access control panel/reader interface. D1 is the Data 1 (Wiegand) or Data (ABA) output. D0 and D1 are capable of transmitting up to 250 feet. Note: <i>The strobe signal is sometimes called 'clock'.</i> CP is the Card Present (ABA) output. The card present signal is low (0 volts DC) during output of ABA token data.	None								
RED & GRN (on J2) Reader LED input	Input for the red and green LED control signal(s) from the access control panel/reader interface. This input is configured using DIP switch 1 for either one-wire LED operation or two-wire LED operation. Two-wire LED operation: Connect the access control panel's/reader interface's red LED output to the RED terminal and the access control panel's/reader interface's green LED output to the GRN terminal. The reader's red LED turns on when the access control panel/reader interface provides 0 volts DC to the input for the red LED. The reader's green LED turns on when the access control panel/reader interface provides 0 volts DC for the green LED. One-wire LED operation: Connect the access control panel's/reader interface's LED output to the RED terminal. The reader's LEDs are controlled as shown below. <table border="1" data-bbox="333 706 655 846"> <thead> <tr> <th>Input signal</th> <th>LED response</th> </tr> </thead> <tbody> <tr> <td>0 volts DC</td> <td>Green LED ON</td> </tr> <tr> <td>5 volts DC</td> <td>Red LED ON</td> </tr> <tr> <td>Not driven</td> <td>Both LEDs OFF</td> </tr> </tbody> </table> Note: <i>The signals provided to the Reader LED input and the Sounder input must be greater than 3.5 volts DC to be interpreted as a 5 volts DC signal. Signals with voltage less than .8 volts DC are interpreted as 0 volts DC (connection to ground (GND)).</i>	Input signal	LED response	0 volts DC	Green LED ON	5 volts DC	Red LED ON	Not driven	Both LEDs OFF	DIP switch 1 configures this input for one-wire or two-wire operation.
Input signal	LED response									
0 volts DC	Green LED ON									
5 volts DC	Red LED ON									
Not driven	Both LEDs OFF									
BPR & GND (on J2) Sounder input	Input for the sounder control signal from the access control panel/reader interface. By default, the lock's sounder turns on when the access control panel/reader interface closes the contact for the sounder, connecting the panel interface circuit board's BPR terminal to ground (GND).	DIP switch 7 provides the ability to invert the interpretation of the sounder input signal.								
12V & GND (on J1) Power input	Input for 12 volts DC at .1 amp power supply. Caution: To prevent damage and injury, connect the power supply after all other connections have been made.	None								

Note: *The two NC terminals on J2 are not used.*

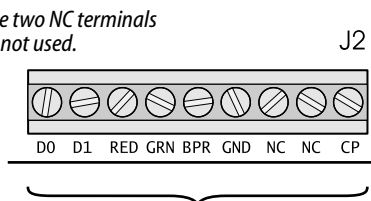

Connect to access control panel/reader interface.

Figure 22b Connecting to the access control panel/reader interface

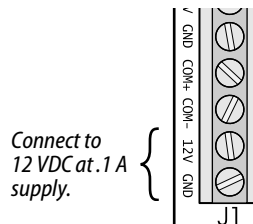

Figure 22c Connecting to the power supply

Installing the panel interface module

24 Set panel interface module DIP switches

Set the DIP switches on the panel interface circuit board. Refer to the table below. Default settings are shown in boldface.

25 Set and connect power supply

- 1 Make sure that the output voltage of the power supply for the panel interface module and lock is set to 15 volts DC or lower.
- 2 Make the final power supply connections.
- 3 Adjust the power supply output voltage to 13.8 volts DC.

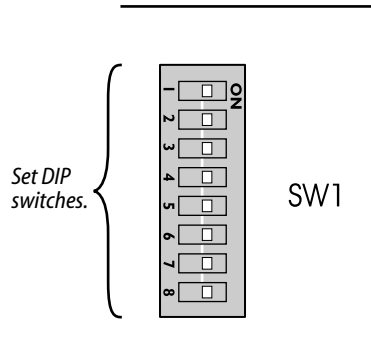

Figure 23 Setting DIP switches

Setting DIP switches

Feature	Option	DIP Switch Setting
Reader LED input configuration Provides the ability to select between one-wire and two-wire LED operation for the reader LED input.	Two-wire operation	Switch 1–ON
	One-wire operation	Switch 1–OFF
Baud rate selection Provides the ability to select the baud rate for communication between the panel interface circuit board and the lock’s control electronics circuit board. Note: To control the baud rate using DIP switches 2 and 3 on the panel interface circuit board, DIP switches 6 and 7 on the control electronics circuit board both must be set to ON (automatic baud rate detection).	38400 bps	Switch 2–OFF Switch 3–OFF
	19200 bps	Switch 2–ON Switch 3–OFF
	9600 bps	Switch 2–OFF Switch 3–ON
	2400 bps	Switch 2–ON Switch 3–ON
Request-to-exit (RQE) status output configuration Provides the ability to invert the request-to-exit (RQE) status signal. If DIP switch 4 is ON, the contact is closed when the door knob/lever is turned, activating the RQE switch.	Normally-open (NO)	Switch 4–ON
	Normally-closed (NC)	Switch 4–OFF
Door status & latchbolt status / Door status output configuration Provides the ability to invert the signal for this output. If DIP switch 8 is ON and DIP switch 5 is ON, the contact is closed when the door is secure (the door status switch & latchbolt status switch are closed). If DIP switch 8 is OFF and DIP switch 5 is ON, the contact is closed when the door is unsecured (the door status switch is closed).	Normally-closed (NC)	Switch 5–ON
	Normally-open (NO)	Switch 5–OFF
Communication tamper / Latchbolt status output configuration Provides the ability to invert the signal for this output. If DIP switch 8 is ON and DIP switch 6 is ON, the contact is closed when the communication connection between the panel interface circuit board and the lock’s control electronics circuit board is OK. If DIP switch 8 is OFF and DIP switch 6 is ON, the contact is closed when the latchbolt is extended (the latchbolt status switch is closed).	Normally-closed (NC)	Switch 6–ON
	Normally-open (NO)	Switch 6–OFF

continued

Installing the panel interface module

Feature	Option	DIP Switch Setting										
Sounder input configuration Provides the ability to invert the interpretation of the sounder input signal. The normal input configuration interprets a closed contact as sounder ON.	Normal input	Switch 7–ON										
	Inverted input	Switch 7–OFF										
Function of TPR terminals and DLS terminals Provides the ability to determine the function of the TPR terminals and DLS terminals, as shown below.	Option 1	Switch 8–ON										
	Option 2	Switch 8–OFF										
	<table border="1"> <thead> <tr> <th data-bbox="64 402 239 467">Configuration option</th> <th data-bbox="239 402 413 467">Function of TPR terminals</th> <th data-bbox="413 402 575 467">Function of DLS terminals</th> </tr> </thead> <tbody> <tr> <td data-bbox="64 467 239 532">Option 1 (Switch 8–ON)</td> <td data-bbox="239 467 413 532">Communications tamper</td> <td data-bbox="413 467 575 532">Door status & latch status</td> </tr> <tr> <td data-bbox="64 532 239 597">Option 2 (Switch 8–OFF)</td> <td data-bbox="239 532 413 597">Latch status</td> <td data-bbox="413 532 575 597">Door status</td> </tr> </tbody> </table>	Configuration option	Function of TPR terminals	Function of DLS terminals	Option 1 (Switch 8–ON)	Communications tamper	Door status & latch status	Option 2 (Switch 8–OFF)	Latch status	Door status		
	Configuration option	Function of TPR terminals	Function of DLS terminals									
Option 1 (Switch 8–ON)	Communications tamper	Door status & latch status										
Option 2 (Switch 8–OFF)	Latch status	Door status										

Testing the installation

Perform the following steps to test the installation. Also, perform any standard testing recommended by the manufacturer of the access control panel. If you encounter problems, see *Troubleshooting the installation*, on page 24.

- 1 Check the control electronics' green status LED and the panel interface module's green status LED.
Both LEDs should be blinking, indicating that the communication connection between the panel interface circuit board and the lock's control electronics circuit board is OK.
- 2 After performing any necessary programming for the lock and putting the door in a locked mode, use a valid token to access the lock.
Confirm that the red reader LED, green reader LED, and sounder respond as expected.
The lock should allow access, verifying that the solenoid is working.
To check that the reader is working, view the lock's event history and verify that the information recorded for the token is correct.
- 3 Use an invalid token to attempt to access the lock.
Confirm that the red reader LED, green reader LED, and sounder respond as expected.
The lock should deny access.
- 4 With the door armed, attempt to exit through the door.
The request-to-exit (RQE) feature should let you exit without triggering an alarm by the access control panel.
- 5 Remove power from the lock and check whether the door remains locked or is unlocked.
Verify that the lock fails safe or secure, according to its function.

- 6 With the door armed, hold the door open. Hold a magnet against the edge of the door, over the door status sensor, until the access control panel sees the door as closed. Then remove the magnet.
Verify that the appropriate alarm response is triggered by the access control panel, indicating that the door status sensor is working.
- 7 With the door armed, hold the door open. Hold a magnet against the edge of the door, over the door status sensor, until the access control panel sees the door as closed. With the magnet in place, push in the latchbolt.
Verify that the appropriate alarm response is triggered by the access control panel, indicating that the latchbolt status sensor is working.

Troubleshooting the installation

To troubleshoot installation problems, refer to the table below. For more information, refer to the *W Series Service Manual* (T60775) and to the documentation provided by the manufacturer of the access control panel/reader interface.

You notice . . .	Possible causes include . . .	You should . . .
<p>Control electronics' green status LED and panel interface module's green status LED are steadily on.</p> <p>Note: <i>You can check the control electronic's green status LED by removing the access door from the inside trim. You can see the reflection of the LED inside the upper-left corner of the trim.</i></p>	<p>Communication between the lock's control electronics circuit board and the panel interface circuit board has been interrupted.</p>	<p>Make sure DIP switches 6 and 7 on the lock's control electronics circuit board are both set to ON (automatic baud rate detection) or to the same positions as DIP switches 2 and 3 on the panel interface circuit board.</p> <p>Check the connections for all communication field wiring.</p> <p>Check the communication connections between the field wire harness and the wire transfer hinge.</p>
<p>Control electronics' green status LED is off.</p>	<p>Power is not being supplied to the lock.</p>	<p>Make sure that the lock's power supply is connected to electrical service.</p> <p>Check the connections for all power field wiring to the lock.</p> <p>Check the power connections between the field wire harness and the wire transfer hinge.</p>
<p>Panel interface module's green status LED is off.</p>	<p>Power is not being supplied to the panel interface module.</p>	<p>Check the connections for power wiring between the panel interface module and the access control panel (or other power source).</p>
<p>A 'door forced' alarm occurs when someone exits through the door.</p>	<p>RQE wiring, and door status and/or latchbolt status wiring, is reversed between the panel interface module and the access control panel/reader interface.</p>	<p>Refer to <i>Connect panel interface module to access control panel/reader interface</i>, on page 19, and correct the wiring problem.</p>