



Instructions for Upgrading B.A.S.I.S. Locks with Zinc Escutcheons to Brass Escutcheons

Planning the upgrade

Overview

These installation instructions describe how to upgrade from zinc escutcheons to brass escutcheons for your:

- 35HG or 35HBV Mortise Lock

or

- 93KG–95KG or 93KBV–95KBV Cylindrical Lock.

This product meets the following Locked Door Outdoor test requirements for ANSI/BHMA 156.25:

Side of door	Range
Inside	+66°F to +74°F (+19°C to +23°C)
Outside	-31°F to +151°F (-35°C to +66°C)

This product meets the following Full Indoor test requirements for ANSI/BHMA 156.25:

Side of door	Range
Inside and outside	+32°F to +120°F (0°C to +49°C)

Contents

The following topics are covered in these instructions.

Planning the upgrade 1

Removing components 2

Installing components 7

Completing the upgrade..... 12

Components checklist

Use the following checklist to make sure that you have the items necessary to upgrade your B.A.S.I.S.® Lock.†

- Inside escutcheon assembly
- Battery compartment door
- Battery pack
- Sensor harness (for mortise locks with black sensor connectors)
- Outside escutcheon assembly
- Hub washers (cylindrical locks)
- Trim hole insert package
- Escutcheon screw package
- Bar code ID sticker (for your records)
- Temporary operator card
- Upgrade instructions

Special tools checklist

Use the following checklist to make sure that you have the special tools necessary to upgrade your lock.

- T15 TORX® bit driver††
- Spanner wrench (for cylindrical locks)
- 1/8" Allen wrench (for mortise locks)

† The Best Access Systems logo and B.A.S.I.S. are registered trademarks of Best Lock Corporation.

†† TORX is a registered trademark of the Camcar Division of Textron.

Removing components

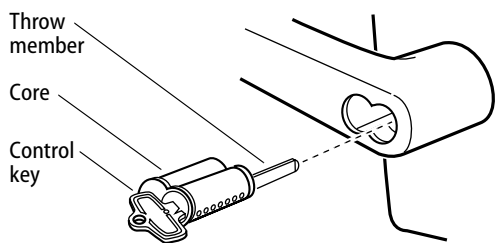

Figure 1 Removing the core and throw member (cylindrical locks)

1 Remove core and throw member (cylindrical locks)

- 1 Insert the control key into the core and rotate the key 15 degrees to the right.
- 2 Remove the core and throw member from the lever.

Removing components

2 Remove inside and outside levers

To remove the outside lever from cylindrical locks

- 1 Insert a flat blade screw driver into the figure-8 core hole and into the lever keeper.
- 2 Press the screwdriver blade in the direction of the arrow shown in Figure 2a.

Note: You will not be able to remove the lever if the screwdriver blade is inserted too far past the keeper.

- 3 Slide the lever off the sleeve.

To remove the inside lever from cylindrical locks

- 1 Insert the protrusion on the spanner wrench into the hole on the shaft of the lever, as shown in Figure 2b.
- 2 Slide the lever off the sleeve.

To remove the levers from mortise locks

- 1 Use a 1/8" Allen wrench to remove the set screw from the inside lever.
- 2 Remove the inside lever, then the outside lever and spindle assembly from the door.

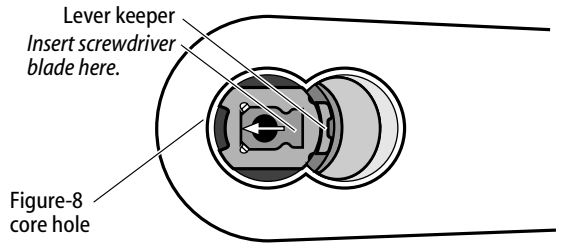

Figure 2a Removing the outside lever from cylindrical locks

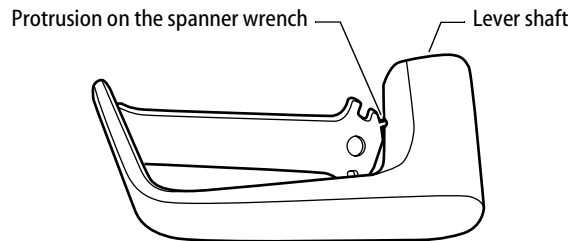

Figure 2b Removing the inside lever from cylindrical locks

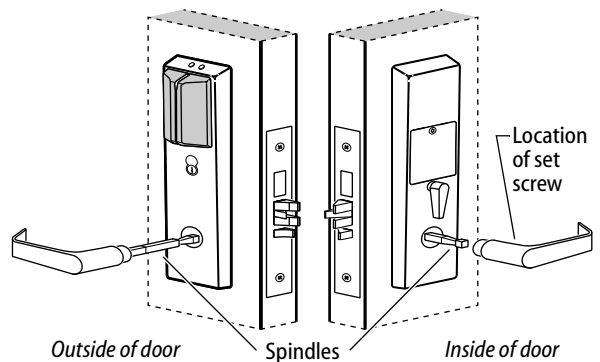

Figure 2c Removing the levers from mortise locks

Removing components

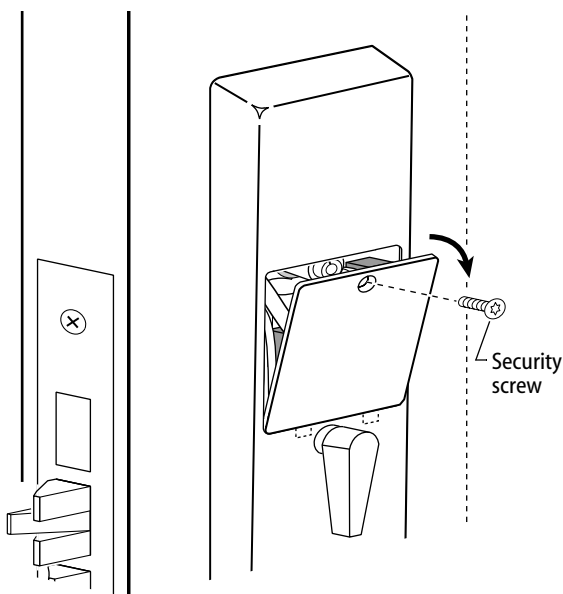

Figure 3 Removing the battery compartment door

3 Remove old battery compartment door

- 1 Use a T15 TORX bit driver to remove the security screw from the battery compartment door.
- 2 Remove the battery compartment door.

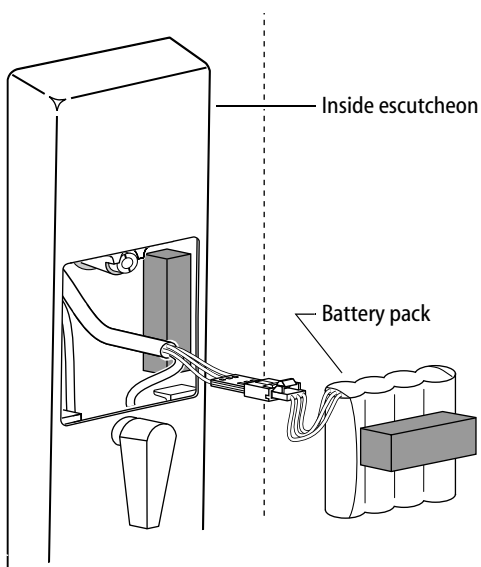

Figure 4 Removing the old battery pack

4 Remove old battery pack

- 1 Remove the battery pack from the battery compartment.
- 2 Disconnect the battery pack.

Removing components

5 Remove old escutcheons

- 1 From the inside of the door, remove the upper and lower escutcheon screws, as shown in Figure 5a.
- 2 Remove the inside escutcheon from the door.
- 3 From the inside of the door, disconnect the motor connector, key override sensor connector (mortise locks with key override sensing), and deadbolt sensor connector (mortise locks with deadbolt sensing). See Figure 5b.
- 4 Remove the outside escutcheon from the door, feeding the motor connector and sensor connectors out the harness hole.

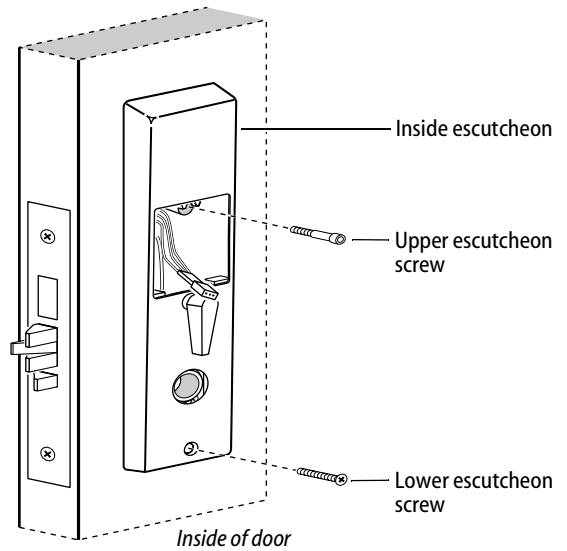

Figure 5a Removing the inside escutcheon

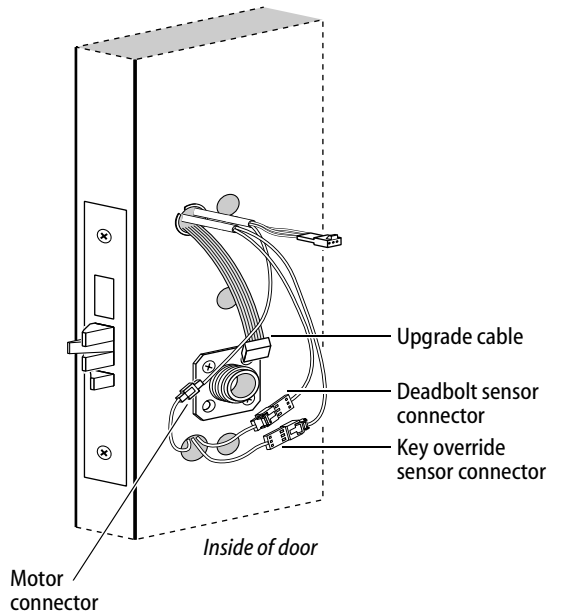

Figure 5b Disconnecting the motor and sensor connectors

Removing components

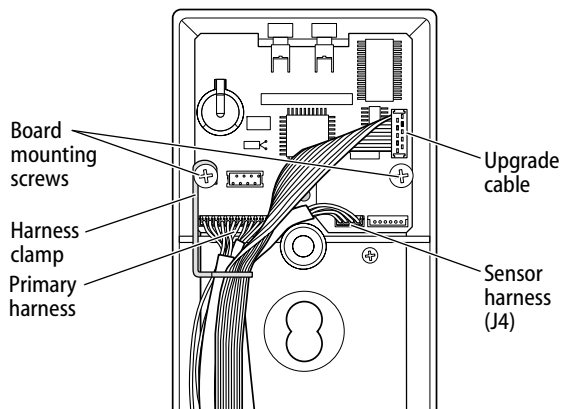

Figure 6 Replacing the sensor harness

6 Replace sensor harness (mortise locks with black sensor connectors)

If this kit was ordered to replace a mortise lock with deadbolt and/or key override sensing, the new outside escutcheon provided has a sensor harness with a small white connector (for deadbolt sensing). If you are upgrading a mortise lock with one or two black connectors coming from the mortise case (for deadbolt sensing and/or key override sensing), you must replace the sensor harness on the new outside escutcheon. A sensor harness is provided in this kit for this purpose.

Caution: Before you handle the electronics board or any component connected to it, make sure that you are properly grounded using an electrostatic discharge (ESD) protection kit! Touching the board without proper grounding can damage sensitive electronics components—even if you don't notice any static discharge!

- 1 Remove the gasket from the new outside escutcheon and save the gasket.
- 2 Loosen the electronics board mounting screw that holds the harness clamp and remove the clamp. Save the clamp.
- 3 Disconnect the sensor harness from the electronics board, as shown in Figure 6.
- 4 Connect the sensor harness with the black sensor connectors to the J4 connector on the electronics board.
- 5 Slide the harness clamp under the loosened electronics board mounting screw.
- 6 Position the primary harness, sensor harness, and upgrade cable under the clamp, as shown in Figure 6.
- 7 Tighten the electronics board mounting screw.
- 8 Slide the escutcheon gasket onto the upper escutcheon post, with the adhesive side down. Press the gasket into place on the edge of the escutcheon so the electronics board is covered.

Installing components

7 Remove backup battery tab

Caution 1: For the lock to operate properly, you must remove the backup battery tab.

Caution 2: Do not connect the battery pack before you have removed the backup battery tab. Doing so may cause the lock to malfunction.

- 1 Locate the backup battery tab on the inside of the new outside escutcheon.
- 2 Pull down on the tab and remove it from the outside escutcheon to turn on the backup battery.

8 Install trim hole inserts, bushings, and hub washers

- 1 Insert the two trim hole inserts into the upper trim hole on each side of the door, as shown in Figure 8.
- 2 Make sure the two bushings are inserted into the harness hole on each side of the door, as shown in Figure 8.
- 3 **For cylindrical locks**, on each side of the door, slide a hub washer over the chassis sleeve so it rests on the hub.

9 Route wire harnesses and position new outside escutcheon

- 1 From the outside of the door, feed the upgrade connector through the harness hole.
- 2 From the outside of the door, feed the motor connector, battery connector, and sensor connectors (mortise locks with key override and/or deadbolt sensing) through the harness hole.

Note: Cylindrical locks and NV function mortise locks do not have a sensor harness.

Caution: When routing the connectors, make sure the harnesses are not routed across any sharp edges or over any surface that could damage their sleeving or wire insulation.

- 3 Rest the outside escutcheon on the door by inserting the trim studs into the trim holes.

Note: You can temporarily install the outside lever to hold the outside escutcheon in place. See task 13 on page 10.

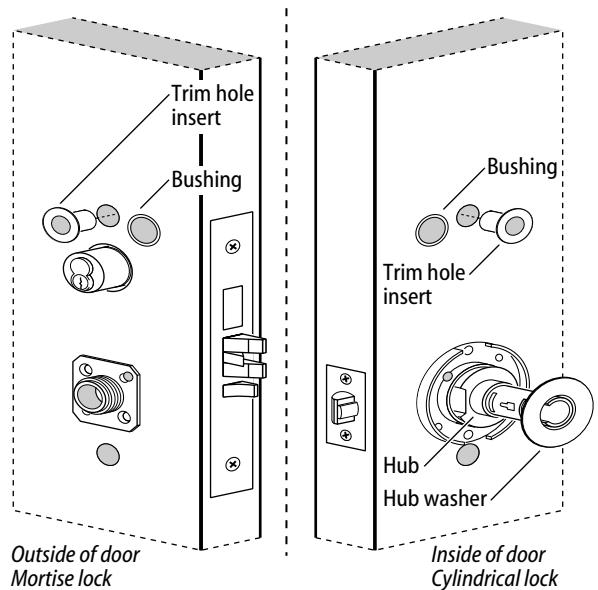

Figure 8 Installing the trim hole inserts, bushings, and hub washers

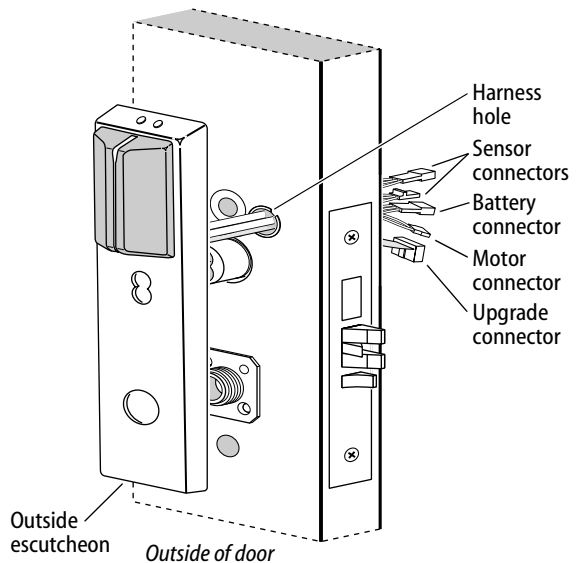

Figure 9 Feeding the wire harness connectors through the harness hole

Installing components

10 Make motor and sensor connections

From the inside of the door, make the motor connection, key override sensor connection (mortise locks with key override sensing), and deadbolt sensor connection (mortise locks with deadbolt sensing).

Note 1: If you installed the sensor harness with black sensor connectors, it is physically possible to connect the key override sensor connector from the mortise case to the battery connector from the wire harness. To avoid this mistake, connect only the connectors with matching wire colors.

Note 2: The upgrade cable is used for reprogramming the lock's firmware without removing the lock from the door. This cable does not connect to a mating lock connector.

Caution: When making the motor connection and sensor connections, make sure:

- there are no loose wire connections where the wires are inserted into the connectors
- the connectors are firmly mated.

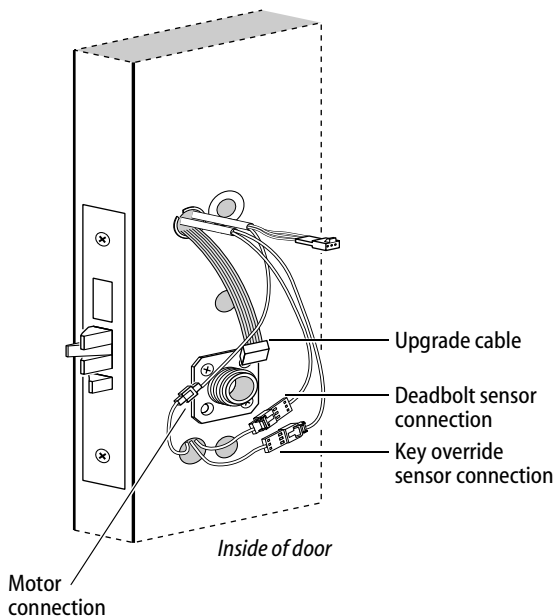

Figure 10 Making the motor connection and deadbolt sensor connection

Wire connection	Colors	No. of wires	No. of pins
Motor	Yellow Gray	2	2
Key override sensor	Gray	2	3
Deadbolt sensor	Blue	2	3

Installing components

11 Secure new escutcheons

- 1 Position the inside escutcheon and outside escutcheon on the door.
- 2 **Making sure that the escutcheons do not pinch the wires**, secure the escutcheons to the door using the new mounting screws provided. Do not tighten the screws completely. Use the combination mounting screw in the upper trim hole and the standard mounting screw in the lower trim hole.

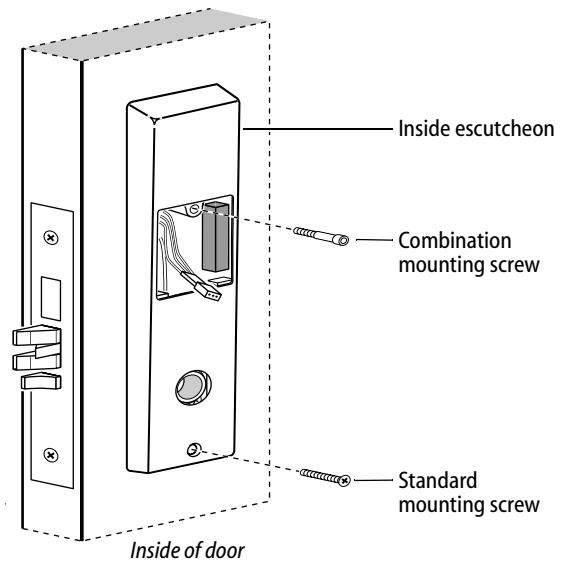

Figure 11 Securing the escutcheons

12 Install new battery pack

- 1 Connect the new battery pack to the battery connector on the wire harness inside the battery compartment.

Note: The battery connection has 3 wires and 3 pins. The wire colors are:

- red with white stripe
- white
- black with white stripe.

Caution: When connecting the battery pack, make sure:

- there are no loose wire connections where the wires are inserted into the connectors
 - the connectors are firmly mated.
- 2 Place the battery pack inside the battery compartment so that the foam will face the battery compartment door.

Caution: When routing the battery wires, make sure the wires are not routed across any sharp edges or over any surface that could damage their sleeving or wire insulation.

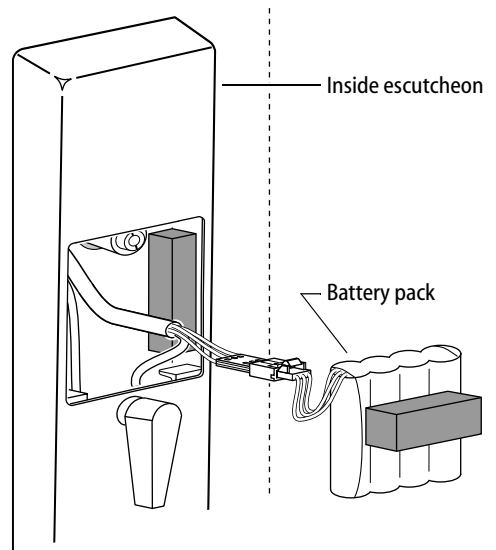

Figure 12 Connecting the battery pack

Installing components

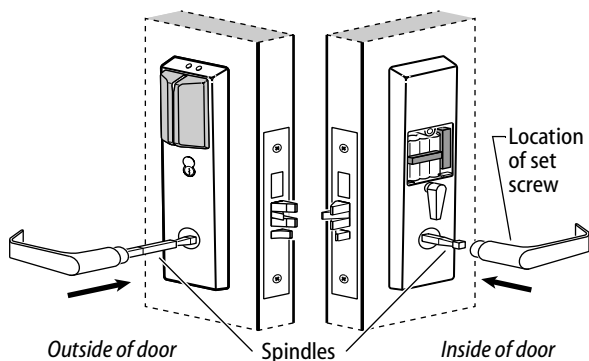

Figure 13a Installing the levers for mortise locks

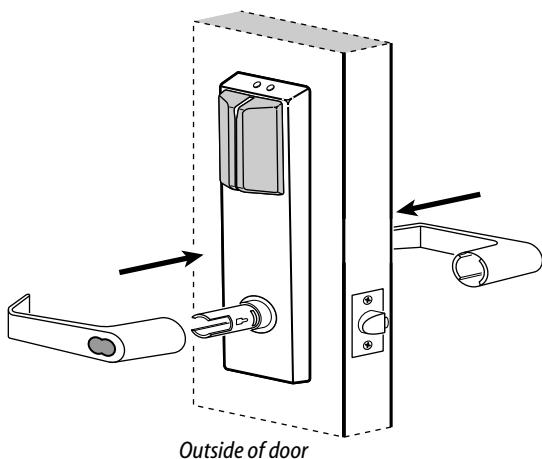

Figure 13b Installing the levers for cylindrical locks

13 Install inside and outside levers

To install the levers for mortise locks

- 1 Unscrew the inside spindle one full turn to allow the spindles to turn freely.
- 2 With the handle pointing toward the door hinges, insert the outside lever and spindle assembly into the lock from the outside of the door.
- 3 Slide the inside lever onto the inside spindle and secure it with the set screw.
- 4 Making sure that the core is positioned properly in the outside escutcheon (EV and FV function mortise locks) and the escutcheons are aligned properly on the door, tighten the escutcheon mounting screws.
- 5 Turn the levers to check that they operate smoothly.

To install the levers for cylindrical locks

Note: To use a core and throw member from a manufacturer other than BEST with a B.A.S.I.S. Cylindrical Lock, see the Installation Instructions for 9K Non-interchangeable Cores & Throw Members (T56093). Skip task 13 and task 14.

- 1 With the handle pointing toward the door hinges, position a lever on the outside sleeve and push firmly on the lever until it is seated. Repeat, placing the other lever on the inside sleeve.
- 2 Tighten the escutcheon mounting screws.
- 3 Turn the levers to check that they operate smoothly.

Installing components

Special tools checklist

14 Install core and throw member (cylindrical locks)

- 1 Install the blocking plate onto the throw member.
Caution: You must use the blocking plate to prevent unauthorized access.
- 2 Insert the control key into the core and rotate the key 15 degrees to the right.
- 3 Insert the throw member into the core.
- 4 Insert the core and throw member into the lever with the control key.
- 5 Rotate the control key 15 degrees to the left and withdraw the key.

Caution: The control key can be used to remove cores and to access doors. Provide adequate security for the control key.

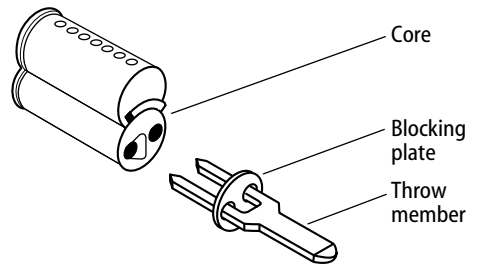

Figure 14a Installing the blocking plate and throw member

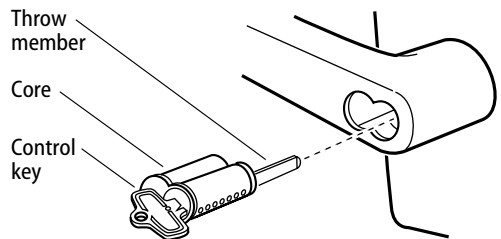

Figure 14b Installing the core

15 Install new battery compartment door

- 1 **Making sure that the battery compartment door does not pinch any wires**, insert the tabs of the battery compartment door into its mating slots and swing the door closed.
- 2 Use a T15 TORX bit driver to secure the battery compartment door with the security screw. Tighten firmly.

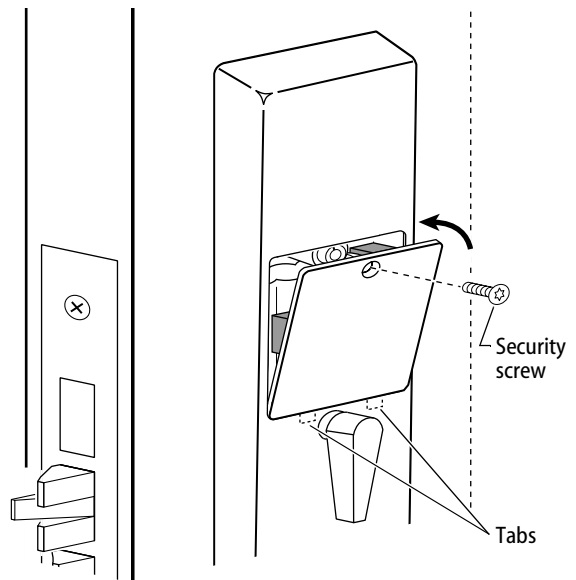

Figure 15 Installing the battery compartment door

Completing the upgrade

16 Test lock

To test the lock for proper operation, use the temporary operator card that came with the lock. This card is for temporary use only. After permanent cards have been programmed for the lock, the temporary card should be deleted.

- 1 Use the temporary operator card to activate the lock. When the lock detects the presence of a card for the first time, it performs a series of diagnostic self-tests. If no problem is detected, the lock responds with 4 red LED flashes, simultaneous with 4 green LED flashes and 4 short tones.

If a problem is detected, the lock's red LED and green LED simultaneously flash in a repeating pattern (and no tones sound). The lock's control electronics board must be replaced. For instructions, see the *B.A.S.I.S. G Service Manual* (T63300) or the *B.A.S.I.S. V Service Manual* (T61805).

Note: *If the lock has a proximity card reader, it may have already been activated by the presences of an object near the card reader.*

- 2 Use the temporary operator card to access the lock. The green light flashes and the locking mechanism unlocks.
- 3 Turn the lever and open the door.

If the mechanism doesn't unlock, refer to the following table. For additional troubleshooting instructions, see the *B.A.S.I.S. G Service Manual* or the *B.A.S.I.S. V Service Manual*.

LEDs	Sounder	You should
Single red flash	—	Use the card at a moderate speed.
Red flashes	3 short tones	Use the temporary operator card provided with the lock.
Green flashes	—	Check the motor connection.
—	—	Check the battery connection.

For all cylindrical locks and for EV and FV function mortise locks

Insert and turn the key to unlatch the door.

For FV and LV function mortise locks

From the inside of the door, turn the turn knob and make sure that the deadbolt operates properly.