



Installation Instructions for IDH Max 1300 Mortise Locks

Overview

The 34HM–35HM IDH Max Mortise Lock provides the following features in an integrated lock, eliminating the need to install separate sensors in and around the door frame:

- electrified locking mechanism
- electronic token reader
- integrated trim
- door status detection
- latchbolt status detection
- ability to exit without triggering an alarm

The figure below shows the relationship between the components in the IDH Max system.

Contents

These installation instructions describe how to install, wire, and configure the components provided with your 34HM–35HM IDH Max Mortise Lock. The following topics are covered.

Site survey 2

Components checklist 2

Special tools checklist 3

Preparing the door and door jamb 4

Installing the lock 8

Completing the installation at the door 15

Testing the installation 19

Troubleshooting the installation 20

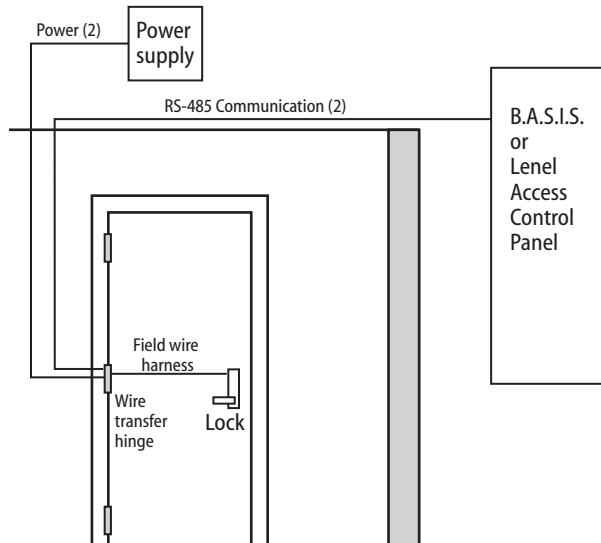

Site survey

Use the following survey to record information about the installation site. You need this information to determine field wiring needs, select a power supply, and determine how to prepare the door for the lock.

Lock information

Lock function:

- EEL—Electrically locked with key
- EEU—Electrically unlocked with key
- NEL—Electrically locked without key
- NEU—Electrically unlocked without key

Power source for lock:

- Separate power supply
- Power provided through the access control panel

Distance of lock site from lock power source: _____ feet

Door information

Door handing and bevel:

- Left hand (LH)
- Left hand, reverse bevel (LHRB)
- Right hand (RH)
- Right hand, reverse bevel (RHRB)

Door thickness: _____ inches (1 3/4" – 3")

Environment information

Ambient temperature:

- Is within specifications. See the tables below.

This product meets the following Locked Door Outdoor test requirements for ANSI/BHMA 156.25:

| Side of door | Range |
|--------------|----------------------------------|
| Inside | +66°F to +74°F (+19°C to +23°C) |
| Outside | –31°F to +151°F (–35°C to +66°C) |

This product meets the following Full Indoor test requirements for ANSI/BHMA 156.25:

| Side of door | Range |
|--------------------|--------------------------------|
| Inside and outside | +32°F to +120°F (0°C to +49°C) |

Use the following checklist to make sure that you have the items necessary to install the components provided with your 34HM–35HM IDH Max Mortise Lock.

Components provided in the box:

- Mortise case assembly
- Mortise case faceplate
- Inside escutcheon assembly with field wire harness
- Inside escutcheon access door
- Outside escutcheon assembly
- Inside and outside mounting plates
- Inside knob/lever
- Outside knob/lever & spindle assembly
- Cylinder assembly (for use with EEL and EEU functions only)
- Mortise screw package
- Trim hole insert package
- Plastic bushing package
- Escutcheon screw package
- Strike
- Strike box with magnet
- Spacer (for 6-pin cores)
- Bar code ID sticker (for your records)

Other items you'll need:

- Power supply for one IDH Max Mortise Lock (if you're providing a separate power supply): regulated; 12 volts DC at 1.1 amps

Note: If you intend to power more than one lock with the same power supply, calculate the amperage for the power supply by multiplying 1.1 by the number of IDH Max Mortise Locks (.85 by the number of IDH Max Cylindrical locks).

- Wire transfer hinge: 8 conductors min.; 28 AWG min.
- continued*

Components checklist

- Field wiring for power connections between the lock and power supply or the lock and access control panel.

If you're powering the lock(s) through the access control panel, calculate the total length of the power wire run by summing:

- The distance from the power supply to the access control panel.
- The distance from the access control panel to the first door.
- If powering more than one door daisy-chained to the same power supply, add the total distance of the power runs between the doors.

If you're powering the lock(s) using a separate power supply, calculate the total length of the power wire run by summing:

- The distance from the power supply to the first door.
- If powering more than one door daisy-chained to the same power supply, add the total distance of the power runs between the doors.

Refer to the table below to determine the minimum wire gauge based on the number of doors sharing the power supply and the total length of the wire run.

| Maximum wire length based on no. of doors daisy-chained to power supply | | | | | Minimum wire gauge |
|---|----------|----------|----------|--------|-----------------------|
| 1 door | 2 doors | 3 doors | 4 doors | | |
| 250 feet | 125 feet | 75 feet | 60 feet | 18 AWG | |
| 400 feet | 200 feet | 130 feet | 100 feet | 16 AWG | |
| 600 feet | 300 feet | 185 feet | 150 feet | 14 AWG | |

- Field wiring for RS-485 communication connections between the lock and access control panel (4000 feet maximum):
Category 5, shielded twisted pair; 24 AWG min.

Special tools checklist

Use the following checklist to make sure that you have the special tools necessary to install the components provided with your 34HM–35HM IDH Max Mortise Lock.

- Three (3) to four (4) foot, 3/8" drill bit
- T15 TORX® bit driver[‡]

[‡] TORX is a registered trademark of the Camcar Division of Textron.

Preparing the door and door jamb

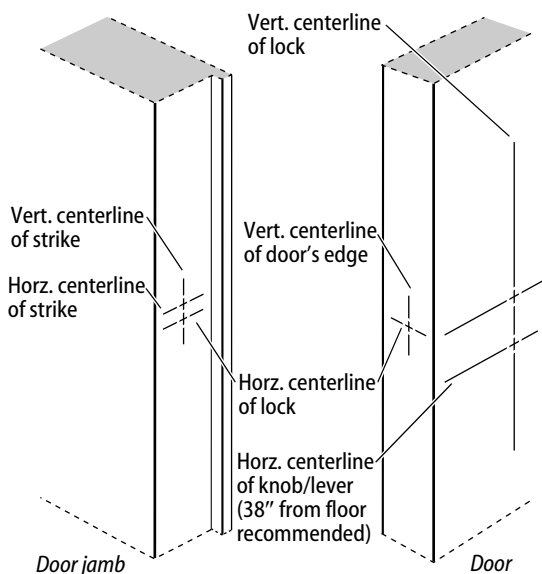

Figure 1 Marking the centerlines

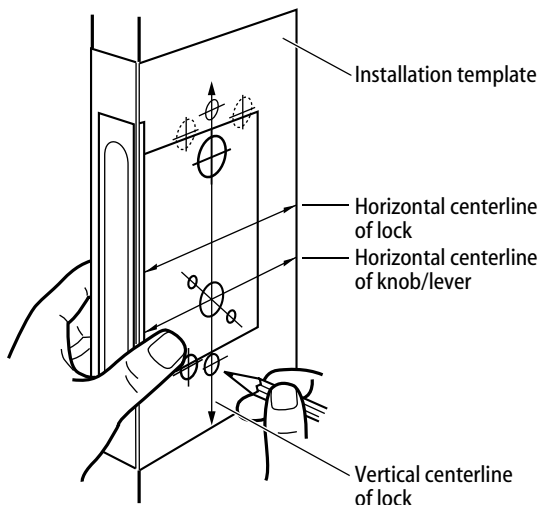

Figure 2 Positioning the template

1 Mark centerlines

Note: If the door is a fabricated hollow metal door, determine whether it is properly reinforced to support the lock. If door reinforcement is not adequate, consult the door manufacturer for information on proper reinforcement. For dimensions for preparing metal doors, see the W13 Template—Installation Specifications for 34HM–35HM IDH Max Mortise Locks.

- 1 On the door, measure and mark the height of the centerline of the knob/lever from the floor (38" recommended). On both sides of the door, on the door's edge, and on the door jamb, mark the horizontal centerline of the lock 1 1/2" above the centerline of the knob/lever.

Note: If the door is a LH or RH door, mark the inside of the door. If the door is a LHRB or RHRB door, mark the outside of the door.

- 2 On the door's edge and door jamb, mark the vertical centerline of the lock.
- 3 Measure and mark the backset (2 3/4" standard) from the vertical centerline on the door's edge. On both sides of the door, mark the vertical centerline of the lock.
- 4 On the door jamb, mark the horizontal centerline of the strike 3/8" above the horizontal centerline of the lock.

2 Position template and mark drill points

- 1 Cut the W15 Template—Installation Template for 34HM–35HM IDH Max Mortise Locks along the dashed lines and align the horizontal and vertical arrows with the marked centerlines on the door.
- 2 Tape the template to the door.
- 3 Center punch the necessary drill points. Refer to the instructions on the template.

Preparing the door and door jamb

3 Mortise for lock case and faceplate

- 1 Mortise the edge of the door for the lock case.
Note: *The mortise cavity depth of 4 5/8" includes clearance for wiring behind the mortise case.*
- 2 Insert the lock in the mortise cavity.
- 3 Mark the outline of the lock faceplate.
- 4 Remove the lock. Mortise to fit the faceplate.

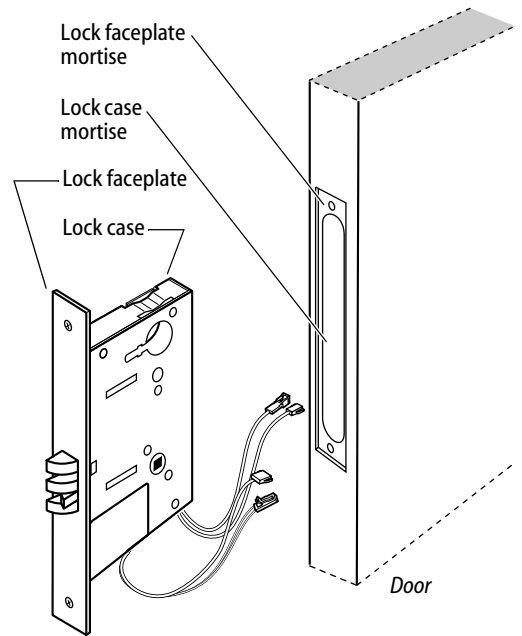

Figure 3 Mortising for the lock case and faceplate

Preparing the door and door jamb

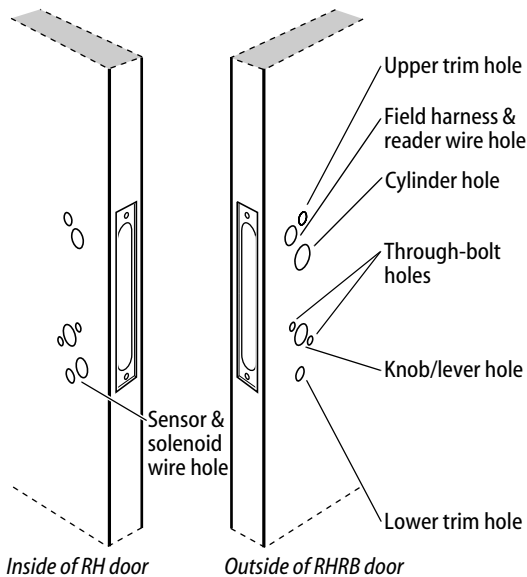

Figure 4a Drilling the RH and RHRB holes

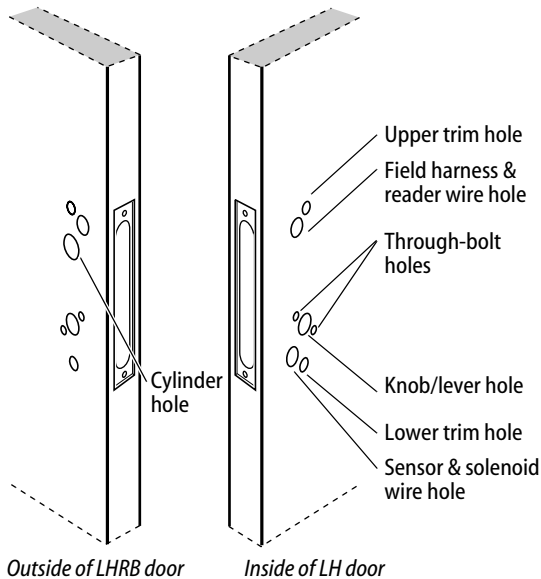

Figure 4b Drilling the LH and LHRB holes

4 Drill holes

Caution: Check for the correct lock function, hand, and bevel before drilling.

Drill the holes listed below:

- upper and lower trim holes
 - ▲ 5/8" diameter
 - ▲ through door
- field harness & reader wire hole
 - ▲ 7/8" diameter
 - ▲ through door
 - ▲ location based on handing
- cylinder hole
 - ▲ 1 1/4" diameter
 - ▲ from outside into mortise cavity
 - ▲ EEL and EEU functions only
- upper and lower through-bolt holes
 - ▲ 3/8" diameter
 - ▲ through door
- knob/lever hole
 - ▲ 7/8" diameter
 - ▲ through door
- sensor & solenoid wire hole
 - ▲ 7/8" diameter
 - ▲ from inside into mortise cavity, approximately 1" deep

Note 1: To locate the center of a hole on the opposite side of the door, drill a pilot hole completely through the door.

Note 2: For holes through the door, it is best to drill half-way from each side of the door to prevent the door from splintering.

Preparing the door and door jamb

5 Drill hole for field wire harness

Caution 1: Check with your local fire marshal before drilling a fire-rated door. Drilling through a fire-rated door may void the fire label.

Caution 2: Be careful to drill straight through the door, making sure the drill does not break through the face of the door.

- 1 Remove the hinge nearest to the mortise cavity.
- 2 Using a three (3) to four (4) foot drill bit, drill a 3/8" diameter hole through the upper back of the mortise cavity to the center of the nearest hinge mortise.

Note: It may be easier to drill halfway from each side of the door.

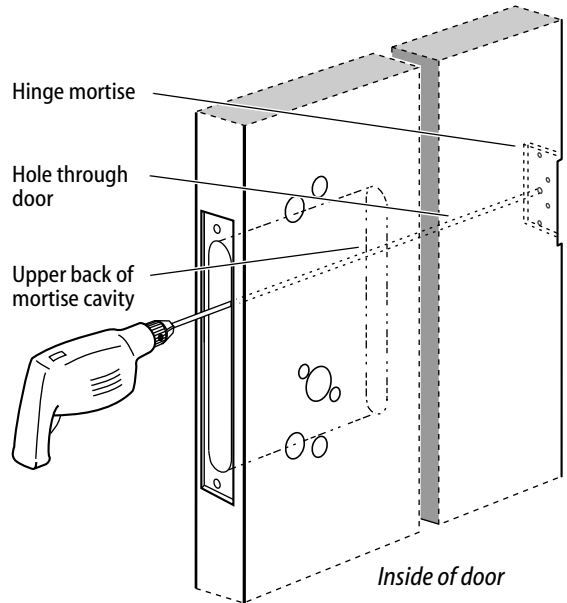

Figure 5 Drilling the hole for the field wire harness

6 Prepare for wire transfer hinge and run field wiring

- 1 Drill a wire access hole through the frame side of the hinge mortise.
- 2 Drill holes (or pockets) for splice connectors in the frame and door. Refer to the hinge manufacturer's specifications for the hole location.
- 3 De-burr the holes to prevent damage to the hinge leads.
- 4 Run the power field wiring from the location for the lock's power supply to the location for the wire transfer hinge.
- 5 Run the communication field wiring from the location for the panel interface module to the location for the wire transfer hinge.

Note: For an overview of the system, see the figure on page 1. For specifications for power and communication field wiring, see Components checklist, on page 2.

- 6 Pull the field wiring down the wall and through the access hole in the frame.

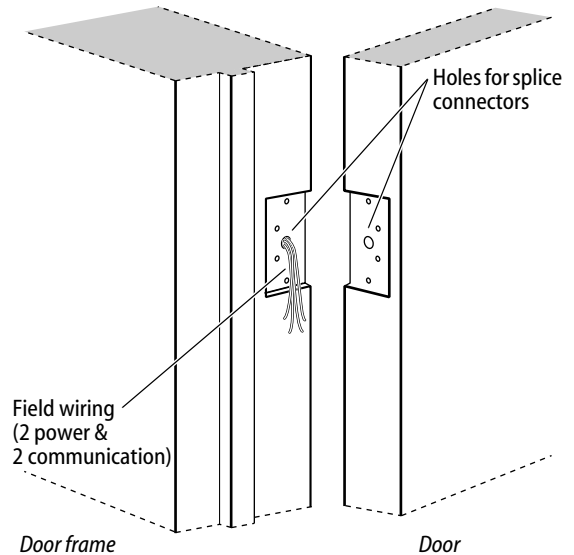
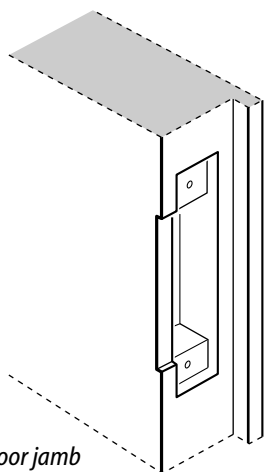

Figure 6 Preparing for the wire transfer hinge

Installing the lock



Door jamb

Figure 7 Mortising the door jamb for the strike box and strike plate

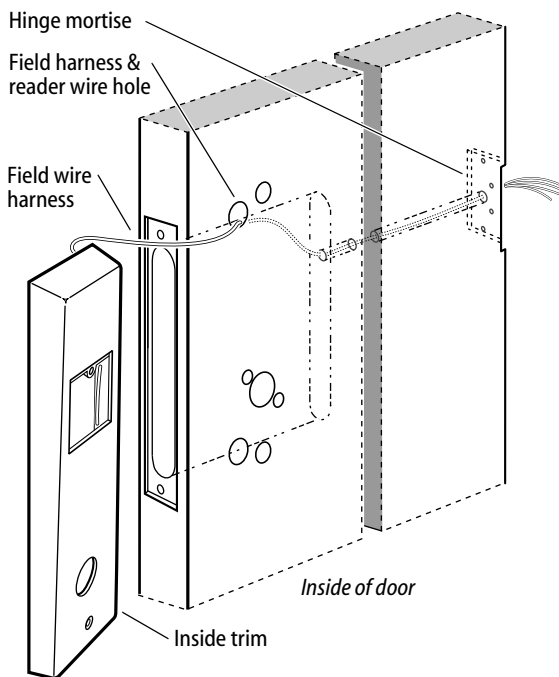

Figure 8 Pulling the field wire harness through the door

7 Mortise for strike box and strike plate

- 1 On the door jamb, locate the horizontal centerline of the strike ($3/8$ " above the centerline of the lock), as well as the vertical centerline of the strike.
- 2 Mortise the door jamb to fit the strike box and strike plate.

8 Pull field wire harness through door

- 1 Feed the field wire harness (connected to the inside trim) into the field harness & reader wire hole and down into the mortise cavity.
- 2 From the hinge edge of the door, fish the field wire harness through the door to the hinge mortise.

Note: You can let the inside trim dangle from the field wire harness while completing tasks 9 through 13.

Installing the lock

9 Install mortise case

- 1 Remove the faceplate from the mortise case.
- 2 Insert the mortise case into the mortise cavity, while feeding the sensor and solenoid wires into the mortise cavity and out the sensor & solenoid wire hole to the inside of the door.

Note: The field wire harness should be routed above and behind the mortise case (depending on where the hole through the door meets the mortise cavity).

- 3 Make sure there are 3" to 4" of slack in the field wire harness to allow access to the control electronics circuit board in the inside trim.
- 4 Secure the mortise case with the case mounting screws.

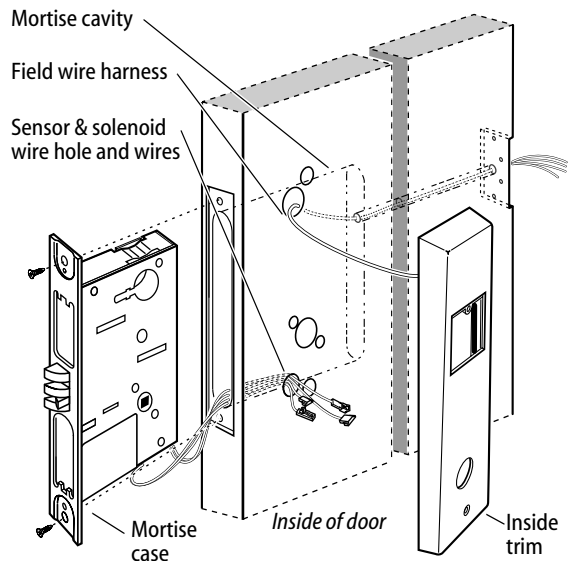

Figure 9 Installing the mortise case

10 Install mounting plates

- 1 Insert the outside mounting plate through the door and mortise case.
- 2 Position the inside mounting plate opposite the outside mounting plate and screw them securely in place.

Caution: Do not overtighten the mounting plate screws. Overtightening may compress the mortise cavity and bind the locking mechanism.

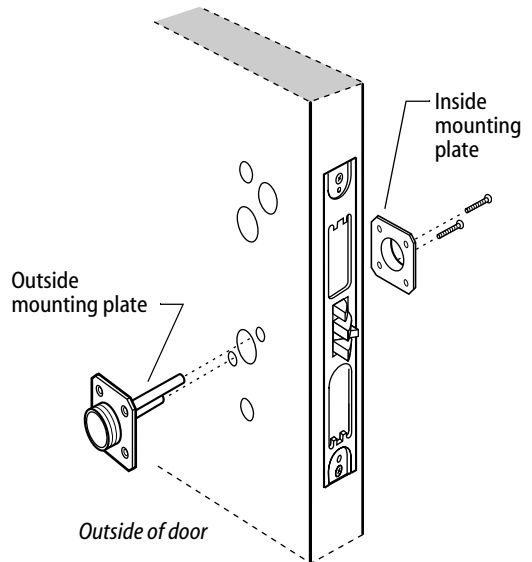

Figure 10 Installing the mounting plates

Installing the lock

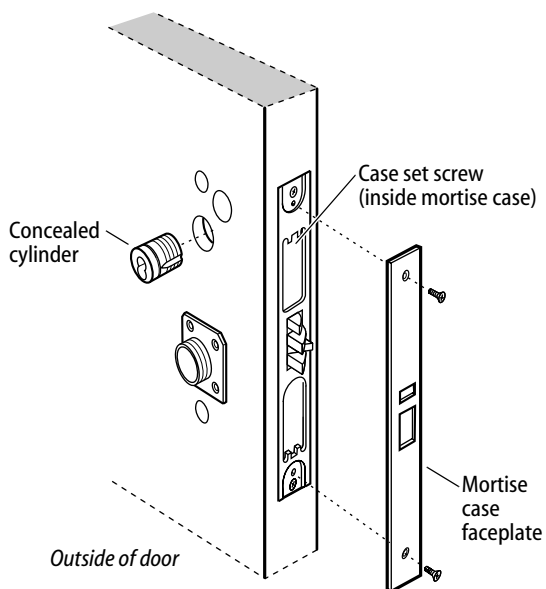

Figure 11 Installing the cylinder and mortise case faceplate

11 Install cylinder and mortise case faceplate

Note: Install the cylinder for EEL and EEU function locks only.

- 1 Thread the concealed cylinder into the mortise case so that the groove around the cylinder head is even with the door surface. Adjust the cylinder depth plus or minus one (1) turn so that the core, when installed in the cylinder, is flush with the outer surface of the trim.

Caution: A malfunction can occur if the cylinder is threaded in too far.

- 2 Secure the cylinder in the mortise case with the case set screw.
- 3 Secure the mortise case faceplate to the mortise case with the faceplate mounting screws.
- 4 Check the cylinder and lock for proper operation.

Installing the lock

12 Install trim hole inserts and bushings

- 1 Insert the two trim hole inserts into the upper trim hole on each side of the door, as shown in Figure 12.
- 2 Insert two bushings into the field harness & reader wire hole on each side of the door, as shown in Figure 12.
- 3 Insert a bushing into the sensor & solenoid wire hole on the inside of the door, as shown in Figure 12.

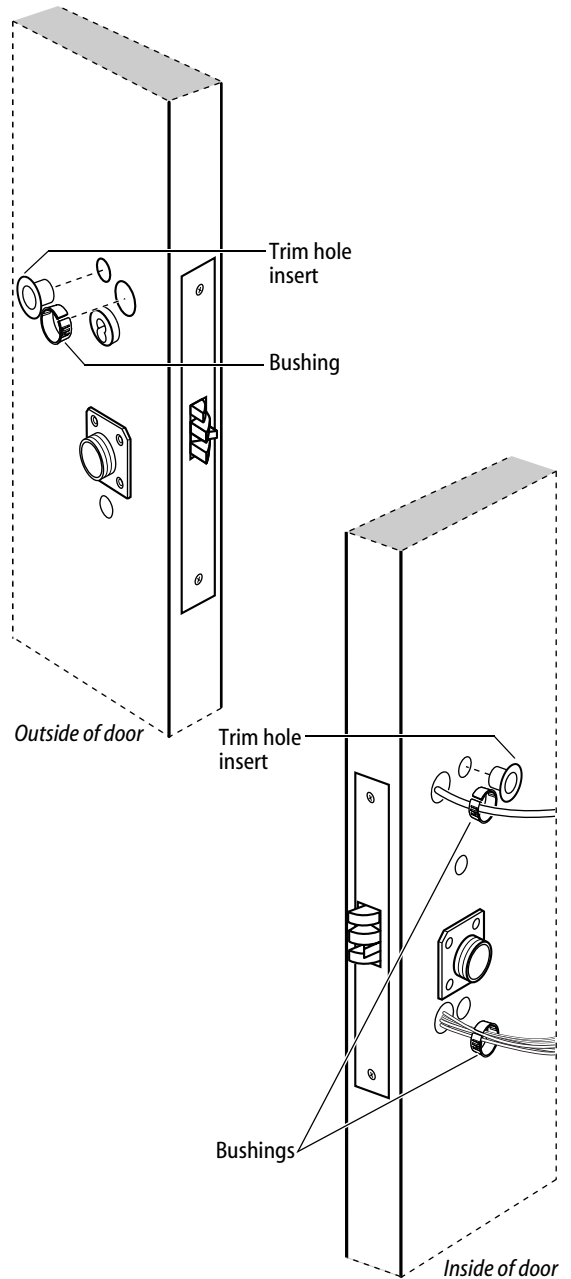

Figure 12 Installing the trim hole inserts and bushings

Installing the lock

Caution 1: When routing the reader wire harness, make sure the reader wire harness is not routed across any sharp edges or over any surface that could damage its sleeving or wire insulation.

Caution 2: When connecting the reader wire harness, make sure:

- there are no loose wire connections where the wires are inserted into the reader wire connector
- the reader wire harness connector is fully seated in its mating connector on the control electronics circuit board.

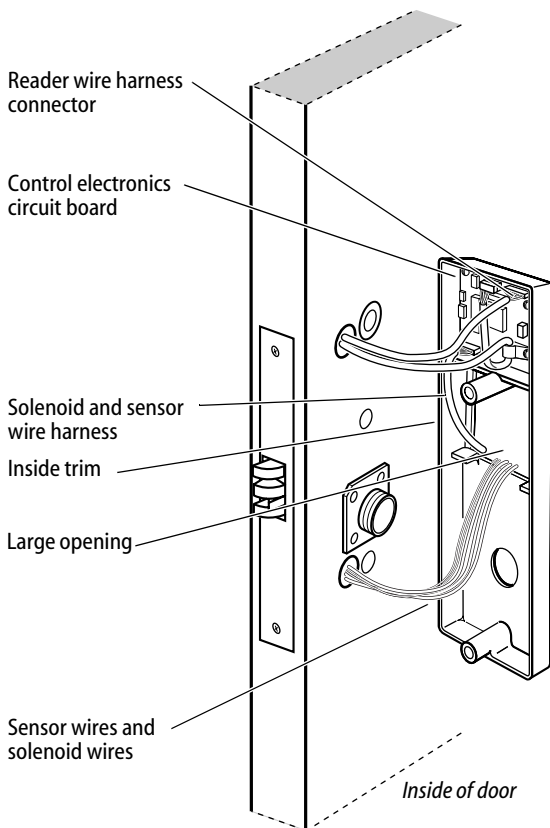

Figure 13b Connecting the reader wire harness to the control electronics circuit board

13 Connect reader wire harness

- 1 From the outside of the door, feed the reader wire harness connector through the field harness & reader wire hole.
- 2 Temporarily rest the outside trim on the door by inserting the trim studs into the stud holes.

Note: You can temporarily install the outside knob/lever to hold the outside trim in place. See Task 15.
- 3 Connect the reader wire harness to the control electronics circuit board in the inside trim.
- 4 Feed the solenoid and sensor wire harness from the control electronics circuit board, as well as the solenoid and sensor wires from the mortise case, through the large opening in the inside trim.

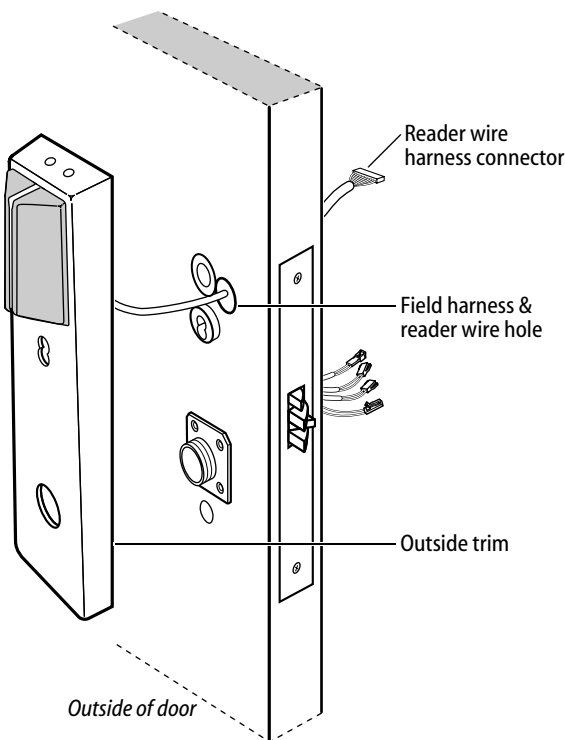

Figure 13a Feeding the reader wire harness connector from the outside trim through the door

Installing the lock

14 Set the control electronics board DIP switches

Each IDH Max unit must be addressable (able to be identified automatically by the access control system) with a unique address that matches its Lenel or B.A.S.I.S.® reader address set up in the management software. See the *System Administration User Guide* for more information on reader addressing.

- 1 On the inside control electronics board use the first five switches to set the reader address in binary code. Switch one is the least significant digit.
- 2 Use the table below to set both switches 6 and 7 to the baud rate at which the locks will communicate with the intelligent controller.

| Baud rate | Switch 6 | Switch 7 |
|-----------|----------|----------|
| 2,400 | All off | |
| 9,600 | | ON |
| 19,200 | ON | |
| 38,400 | ON | ON |

- 3 *For the last IDH Max Lock in the daisy-chain only*, set switch 8 to ON. Otherwise, set switch 8 to OFF.

Installing the lock

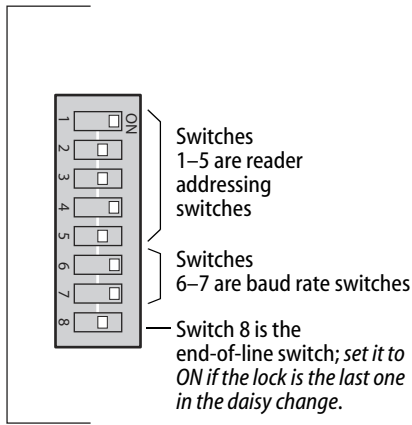

Figure 14 DIP switches on the Control Electronics circuit board set to reader address 5 and 38,400 bps baud rate and not end of line.

For example, to address an IDH Max Lock with address number 5, the binary equivalent number would be 00101 – OFF OFF ON OFF ON. See table below.

| Reader address | (16) Switch 5 | (8) Switch 4 | (4) Switch 3 | (2) Switch 2 | (1) Switch 1 |
|----------------|---------------|--------------|--------------|--------------|--------------|
| 0 | | | All off | | |
| 1 | | | | | ON |
| 2 | | | | ON | |
| 3 | | | | ON | ON |
| 4 | | | ON | | |
| 5 | | | ON | | ON |
| 6 | | | ON | ON | |
| 7 | | | ON | ON | ON |
| 8 | | ON | | | |
| 9 | | ON | | | ON |
| 10 | | ON | | ON | |
| 11 | | ON | | ON | ON |
| 12 | | ON | ON | | |
| 13 | | ON | ON | | ON |
| 14 | | ON | ON | ON | |
| 15 | | ON | ON | ON | ON |
| 16 | ON | | | | |
| 17 | ON | | | | ON |
| 18 | ON | | | ON | |
| 19 | ON | | | ON | ON |
| 20 | ON | | ON | | |
| 21 | ON | | ON | | ON |
| 22 | ON | | ON | ON | |
| 23 | ON | | ON | ON | ON |
| 24 | ON | ON | | | |
| 25 | ON | ON | | | ON |
| 26 | ON | ON | | ON | |
| 27 | ON | ON | | ON | ON |
| 28 | ON | ON | ON | | |
| 29 | ON | ON | ON | | ON |
| 30 | ON | ON | ON | ON | |
| 31 | ON | ON | ON | ON | ON |

Completing the installation at the door

15 Secure through-bolt trim and complete connections

- 1 Position the inside and outside trim onto the door.
- 2 **Making sure that the trim does not pinch the wires**, secure the trim to the door—but do not tighten. Use the combination mounting screw at the top trim hole and the standard mounting screw at the bottom trim hole.

Caution: When routing the solenoid and sensor wire harness, the sensor wires, and the solenoid wires, make sure the wires are not routed across any sharp edges or over any surface that could damage their sleeving or wire insulation.

- 3 Make the solenoid connection and three sensor connections, and place the wires into the inside trim.

| Wire connection | Color | No. of wires | No. of pins |
|---------------------|------------------|--------------|-------------|
| Solenoid | Yellow | 2 | 3 |
| RQE | Brown/ Orange | 2 | 3 |
| Latch status sensor | Purple | 2 | 2 |
| Door status sensor | White | 2 | 2 |

Caution: When making the sensor connections and solenoid connection, make sure:

- there are no loose wire connections where the wires are inserted into the connectors
- the connectors are firmly mated.

16 Install inside and outside knobs/levers

For both knobs and levers

Unscrew the inside spindle one (1) full turn to allow the spindles to turn freely.

For knobs

- 1 From the outside of the door, insert the outside knob and spindles assembly into the lockset.

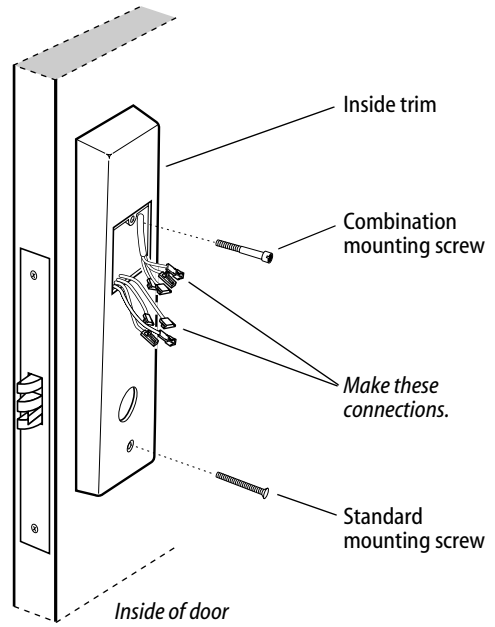

Figure 15 Securing the through-bolt trim and completing connections

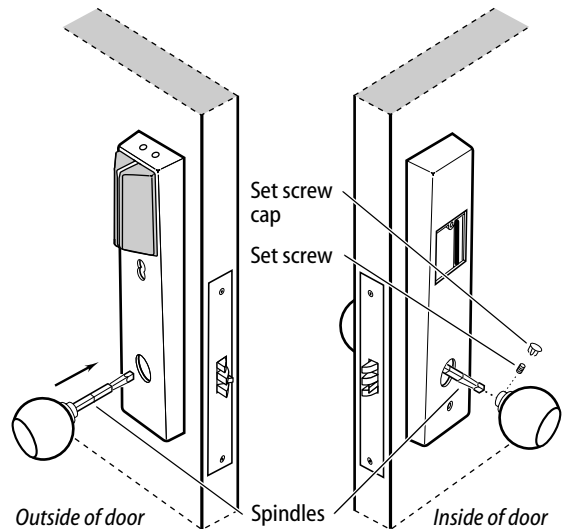

Figure 16a Installing the knobs

Completing the installation at the door

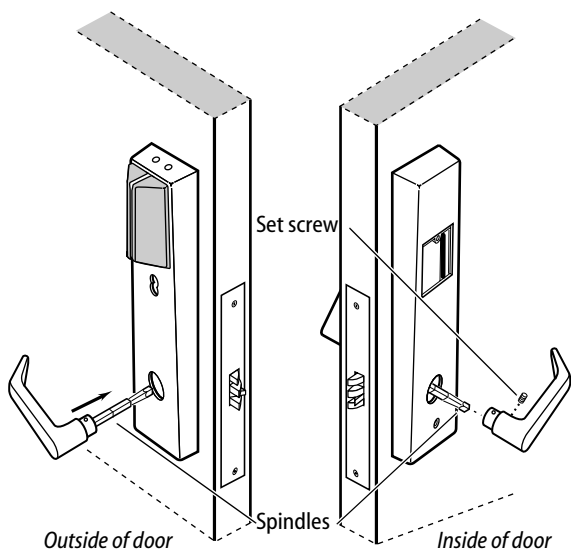

Figure 16b Installing the levers

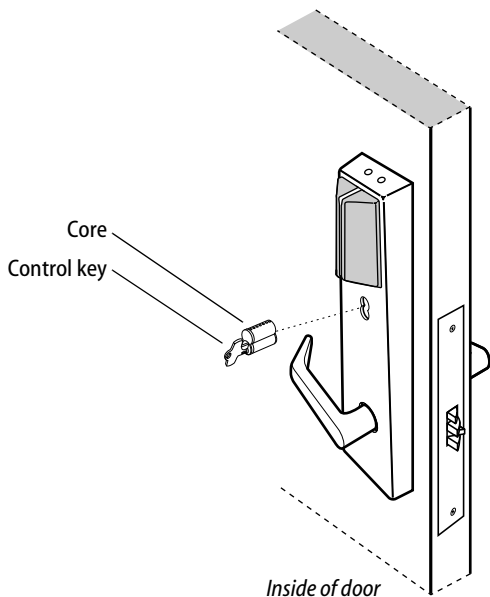

Figure 17 Installing the core

- 2 Slide the inside knob onto the inside spindle and secure it with the set screw.
- 3 Push the set screw cap into the set screw hole.
- 4 Tighten the trim mounting screws.
- 5 Turn the knobs to check that they operate smoothly.

For levers

- 1 With the handle pointing toward the door hinges, insert the outside lever and spindles assembly into the lock from the outside of the door.
- 2 Slide the inside lever onto the inside spindle and secure it with the set screw.
- 3 Tighten the trim mounting screws.
- 4 Turn the levers to check that they operate smoothly.

17 Install core (EEL and EEU only)

- 1 Insert the control key into the core and rotate the key 15 degrees to the right.
- 2 With the control key in the core, insert the core into the cylinder.
- 3 Rotate the control key 15 degrees to the left and withdraw the key.

Caution: The control key can be used to remove cores and to access doors. Provide adequate security for the control key.

Completing the installation at the door

18 Install access door

- 1 **Making sure that the access door does not pinch any wires**, insert the tabs of the access door into its mating slots and swing the door closed.
- 2 Use a T15 TORX bit driver to secure the access door with the security screw. Tighten firmly.

19 Install wire transfer hinge

- 1 Trim the four wires of the field wire harness, which you pulled through the hinge edge of the door in Task 8. Leave sufficient length to connect to the wire transfer hinge.
- 2 Splice the power and communication field wiring to the four pairs of leads on the frame side of the hinge, following the hinge manufacturer's instructions.
- 3 Splice the four field wire harness wires (listed in the table below) to the four pairs of leads on the door side of the hinge, matching each pair of leads to its corresponding field wire.

| Wire | Color |
|--------|--------|
| Ground | Black |
| 12 VDC | Red |
| Com+ | Orange |
| Com- | Green |

- 4 Insert the wires and splice connectors into the holes or pockets in the door and frame, being careful not to pinch the wires. Install the wire transfer hinge.

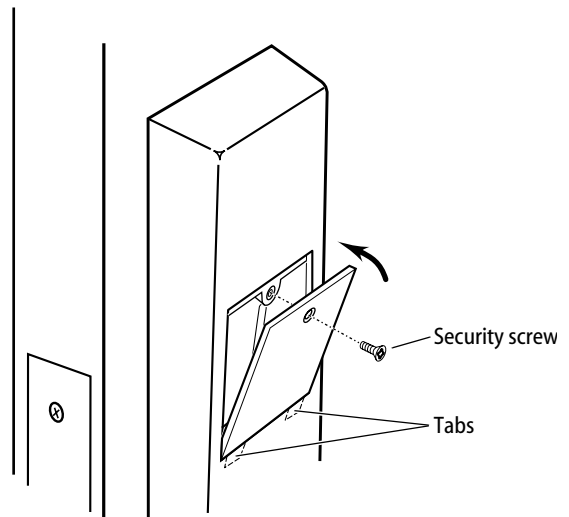

Figure 18 Installing the access door

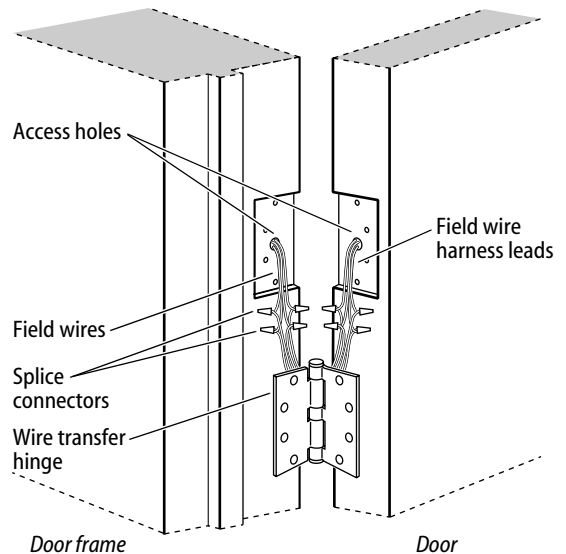

Figure 19 Installing the wire transfer hinge

Completing the installation at the door

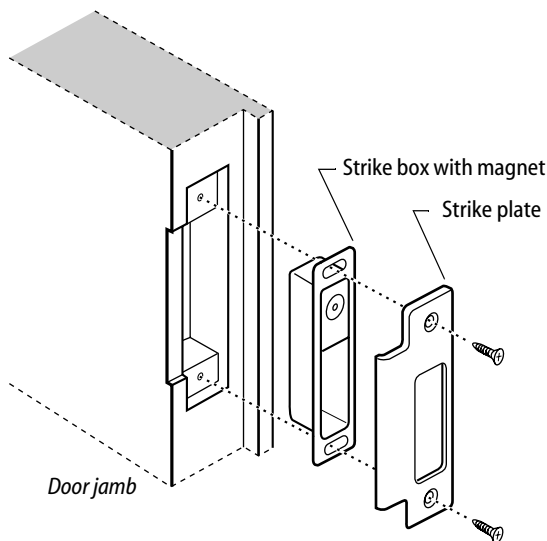

Figure 20a Installing the strike box and strike plate

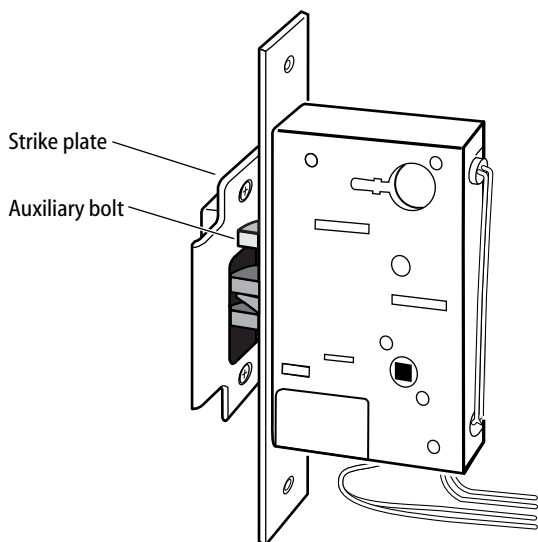

Figure 20b Positioning the strike

20 Install strike box and strike plate

- 1 Insert the strike box into the mortise in the door jamb. Place the strike plate over the strike box and secure the strike with the screws provided.
- 2 Check the position of the auxiliary bolt against the strike plate.

Caution: The auxiliary bolt must make contact with the strike plate. The auxiliary bolt deadlocks the latchbolt and prevents someone from forcing the latch open when the door is closed. If the incorrect strike is installed, a lock-in can occur.

Note: The recommended gap between the door and jamb is 1/8".

21 Optional: Install lock power supply

If you are providing a separate power supply for the lock, instead of providing power via the panel interface module, connect the two power field wires (run from the wire transfer hinge) to the power supply. Make sure power (12 volts DC) and ground are connected properly.

Follow the instructions provided by the power supply manufacturer. Do not plug in the power supply yet.

Note: For specifications for the power supply, see Components checklist, on page 2.

Testing the installation

22 Connect to the BAS-500 or BAS-1000 access control panel

- 1 If necessary daisy-chain all IDH Max Locks by splicing like wires and make all necessary wire runs to either a BAS-500 or BAS-1000 panel.

Note: A BAS-500 panel will accept up to 16 IDH Max 1300 locks and a BAS-1000 panel will accept up to 32 IDH Max 1300 locks.

- 2 Connect the orange wire or its extension to the RS485 connection TR2+ or higher. See Figure 22.
- 3 Connect the green wire or its extension to the RS485 connection TR2- or higher.
- 4 Connect the shield strand to the RS485 connection GND (ground).

23 Test the installation

After downloading the panel information to the IDH Max Locks, perform the following steps to test the installation. Also, perform any standard testing recommended by the manufacturer of the access control panel. If you encounter problems, see *Troubleshooting the installation*, on page 20.

- 1 Check the control electronics' red status LED.
Both LEDs should be blinking red, indicating that the communication connection between the access control panel and the lock's control electronics circuit board is OK.
- 2 After performing any necessary programming for the lock and putting the door in a locked mode, use a valid token to access the lock.
Confirm that the red reader LED, green reader LED, and sounder respond as expected.
The lock should allow access, verifying that the solenoid is working.
To check that the reader is working, view the lock's event history and verify that the information recorded for the token is correct.
- 3 Use an invalid token to attempt to access the lock.

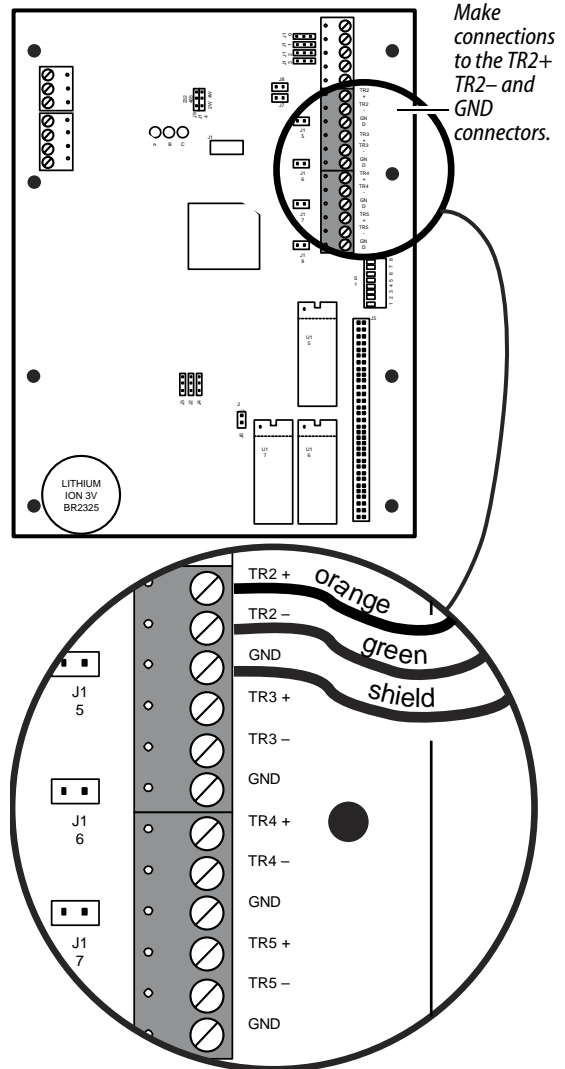

Figure 22 Making connections to the access control panel, BAS-1000 shown.

Troubleshooting the installation

- Confirm that the red reader LED, green reader LED, and sounder respond as expected.
The lock should deny access.
- 4 With the door armed, attempt to exit through the door.
The request-to-exit (RQE) feature should let you exit without triggering an alarm by the access control panel.
- 5 Remove power from the lock and check whether the door remains locked or is unlocked.
Verify that the lock fails safe or secure, according to its function.
- 6 With the door armed, hold the door open. Hold a magnet against the edge of the door, over the door status sensor, until the access control panel sees the door as closed. Then remove the magnet.
Verify that the appropriate alarm response is triggered by the access control panel, indicating that the door status sensor is working.

- 7 With the door armed, hold the door open. Hold a magnet against the edge of the door, over the door status sensor, until the access control panel sees the door as closed. With the magnet in place, push in the latch-bolt.
Verify that the appropriate alarm response is triggered by the access control panel, indicating that the latch-bolt status sensor is working.

Troubleshooting

To troubleshoot installation problems, refer to the table below. For more information, refer to the *IDH Max Lock Service Manual* (T60775) and to the documentation provided by the manufacturer of the access control panel/reader interface.

| You notice . . . | Possible causes include . . . | You should . . . |
|--|---|---|
| Control electronics' red status LED and access control panel's red status LED are on only 20% of the time. | Communication between the lock's control electronics circuit board and the access control panel has been interrupted. | <p>Make sure DIP switches 6 and 7 on the lock's control electronics circuit board are set to the proper baud rate. See page 13.</p> <p>Check the connections for all communication field wiring.</p> <p>Make sure that the last daisy-chained IDH Max DIP switch is set to ON and all others are OFF. See page 13.</p> <p>Check the communication connections between the field wire harness and the wire transfer hinge.</p> |
| Control electronics' red status LED is off. | Power is not being supplied to the lock. | <p>Make sure that the lock's power supply is connected to electrical service.</p> <p>Check the connections for all power field wiring to the lock.</p> <p>Check the power connections between the field wire harness and the wire transfer hinge.</p> |