

Installation Instructions for 45HM IDH Max® 1300 Mortise Locks

The 45HM IDH Max® 1300 Mortise Lock provides the following features in an integrated lock, eliminating the need to install separate sensors in and around the door frame:

- electrified locking mechanism
- electronic token reader
- integrated trim
- door status detection
- ability to exit without triggering an alarm (RQE)

The figure below shows the relationship between the components in the IDH Max® System.

For hole sizes, see the W28 Template (T81625)

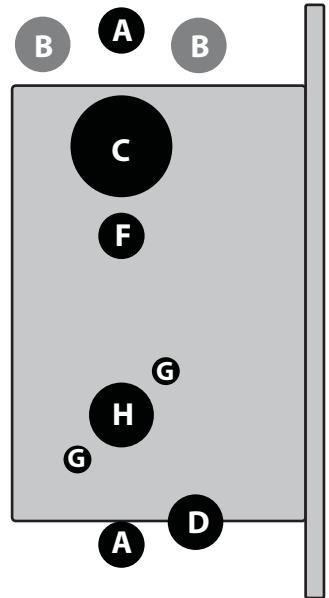
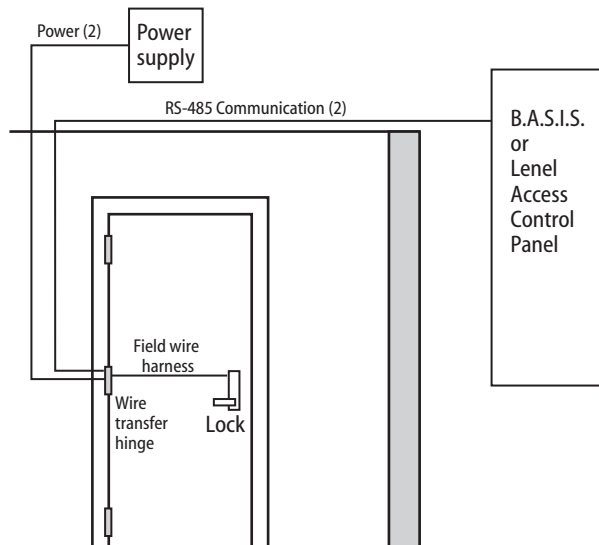

Figure 1 Identifying holes to drill



Functions

Holes by Function	DEU/DEL		LEU/LEL		NXEU/NXEL		TDEU/TDEL	
	I/S	O/S	I/S	O/S	I/S	O/S	I/S	O/S
A Forged trim (2 holes) [†]	Through door		Through door		Through door		Through door	
B Harness [†]	Through door		Through door				Through door	
C Standard cylinder		■						■
D Sensor & solenoid wire	■		■		■		■	
F Thumb turn			■				■	
G Trim mounting (2 holes) [†]	Through door		Through door		Through door		Through door	
H Lever [†]	Through door		Through door		Through door		Through door	

[†] Because these holes pass through the mortise pocket, it is recommended that each hole be drilled separately rather than straight through.

1 Identify holes to drill

- 1 Determine the lock function to be installed.
- 2 Determine the inside and outside, hand, and bevel of the door.
- 3 See the *Holes by Function* table and Figure 1 to determine the holes to be drilled for the lock function.

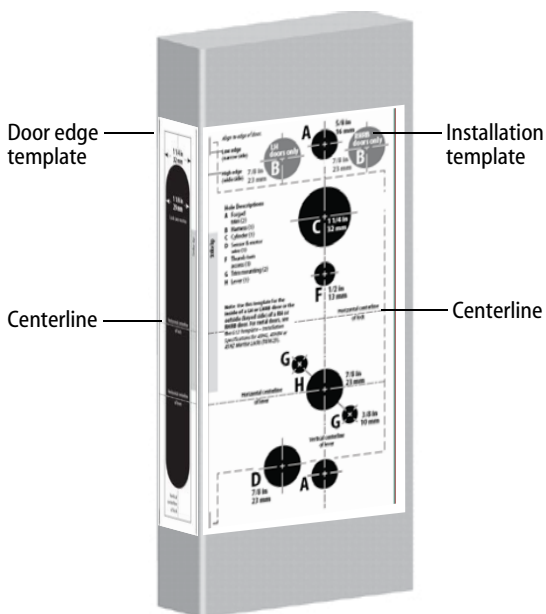

Figure 2 Aligning the templates

2 Align templates

Note: If the door is a fabricated hollow metal door, determine whether it is properly reinforced to support the lock. If door reinforcement is not adequate, consult the door manufacturer for information on proper reinforcement. For dimensions for preparing metal doors, see the W29 Template – Installation Specifications for 45HM IDH Max Mortise Locks (T81630).

- 1 Separate the four templates provided on the W28 Template—Installation Template for 45HM IDH Max Mortise Locks (T81625).
- 2 Position one of the door edge templates on the door, making sure that the lock case mortise shown on the template aligns with the mortise pocket prepared in the door.
- 3 Using the centerlines on the door edge template as a guide, position the appropriate door template on each side of the door. You need to take the bevel into account. Tape the templates to the door.

3 Drill wire channel through door

Caution 1: Check with your local fire marshal before drilling a fire-rated door. Drilling through a fire-rated door may void the fire label.

Caution 2: Be careful to drill straight through the door, making sure the drill does not break through the face of the door.

- 1 Remove the hinge nearest the mortise cavity.
- 2 Using a 3 to 4 foot drill bit, drill a 3/8" diameter channel through the upper back of the mortise cavity to the center of the nearest hinge mortise. See Figure 3.

Note: It may be easier to drill halfway from each side of the door.

4 Optional: Prepare door for door status switch (for deadbolt function locks with door sensing only)

- 1 Locate the centerpoint for the door status switch 2.5" above the top of the faceplate mortise on the edge of the door (as shown in Figure 4).
- 2 Drill a 1" diameter hole 1 3/4" deep for the door status switch.
- 3 Position the drill so the tip of the bit is approximately 1" into the hole and the bit is close to the top edge of the hole. Then drill a 3/8" channel at approximately a 35° angle from the door status switch hole into the mortise cavity (as shown in Figure 4).

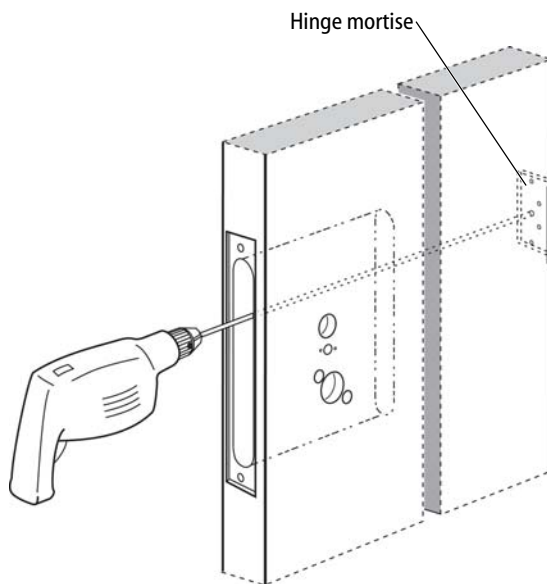

Figure 3 Drilling the wire channel through the door

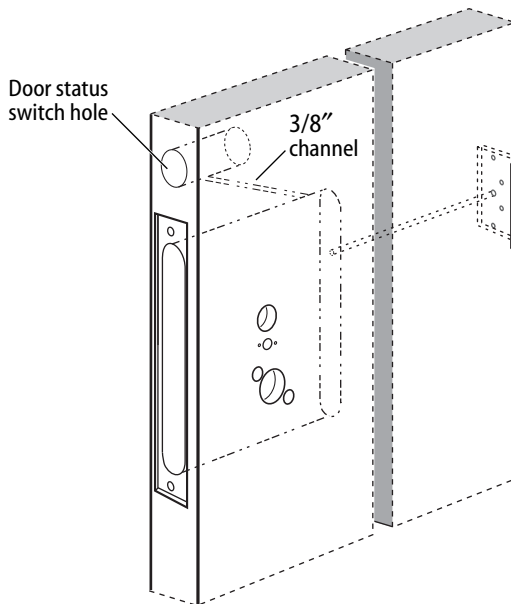

Figure 4 Preparing for the door status switch

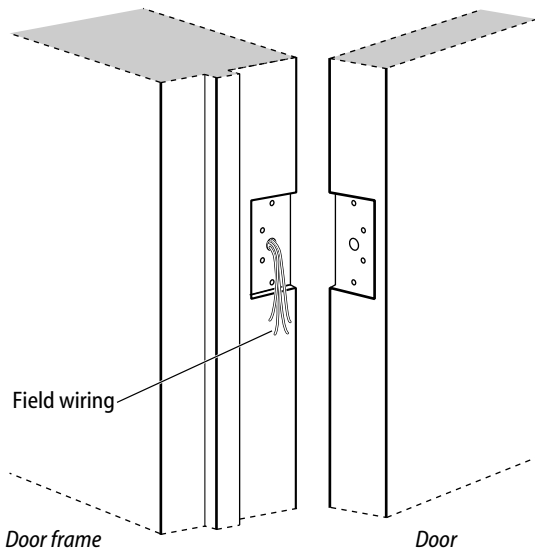

Figure 6 Running field wiring

5 Determine wire gauge for power wiring

- Calculate the total length of the power wire run by summing:
 - The distance from the power supply to the first door.
 - If powering more than one door daisy-chained to the same power supply, add the total distance of the power runs between the doors.
- Refer to the table below to determine the minimum wire gauge based on the number of doors sharing the power supply and the total length of the wire run.

1 door	2 doors	3 doors	4 doors	Min. wire gauge
250 ft.	125 ft.	75 ft.	60 ft.	18 AWG
400 ft.	200 ft.	130 ft.	100 ft.	16 AWG
600 ft.	300 ft.	185 ft.	150 ft.	14 AWG

6 Prepare door for wire transfer hinge and run field wiring

- Drill a wire access hole through the frame side of the hinge mortise where you removed the hinge in Task 3, Step 1 on page 3.
- Drill holes (or pockets) for splice connectors in the frame and door. Refer to the hinge manufacturer's specifications for the hole location.
- De-burr the holes to prevent damage to the hinge leads.
- Run the power field wiring from the location for the lock's power supply to the location for the wire transfer hinge.

Note 1: To match the lock's wire color, use yellow for 12 volts DC power.

Note 2: To minimize lever temperature, install an 8WTCM (temperature control module) in series with the power and ground wiring within 20 feet of the lock. Use only one 8WTCM per lock. This module is supplied with electrically locked (EL) functions and is optional with electrically unlocked (EU) functions.

– Continued

Configuring & installing the mortise case

- Run the sensor wiring from the location of the access control panel to the location for the wire transfer hinge.
To match the sensor wire colors, refer to the table below.

Wire connection	Color	No. of wires
Door status sensor	White	2
Latchbolt status sensor	Purple	2
RQE status sensor	Brown & Orange	2

- Pull the field wiring down the wall and through the access hole in the frame.

7 Optional: Install door status switch (for deadbolt function locks with door sensing only)

- Position the shield on the door status switch with the notch facing downwards (towards the mortise pocket).
Caution: Make sure the wires are not routed across any sharp edges or over any surface that could damage its sleeving.
- Feed the wires for the door status switch into the door status switch hole and through the channel into the mortise cavity.
- Insert the door status switch assembly into the door status switch hole.

8 Rotate latchbolt (if necessary)

Note: If a function specific mortise case was ordered, some steps for configuring the case have already been performed at the factory.

- Determine whether you need to rotate the latchbolt to match the handing of the door.
Note: The angled surface of the latchbolt must contact the strike when the door closes.
- If you need to rotate the latchbolt, insert a flat blade screwdriver into the latch access point approximately 1/2" into the case and press to extend the latch out of the case. See Figure 8.
- Rotate the latchbolt 180 degrees and allow it to retract into the case.

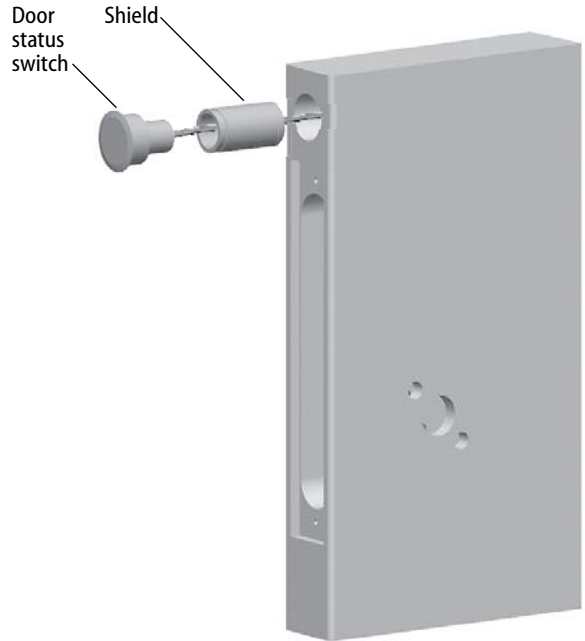

Figure 7 Installing the door status switch

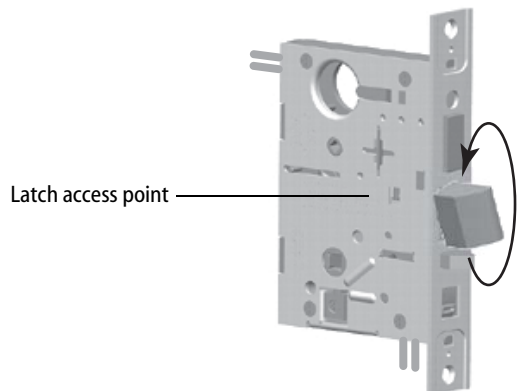

Figure 8 Rotating the latchbolt

Configuring & installing the mortise case

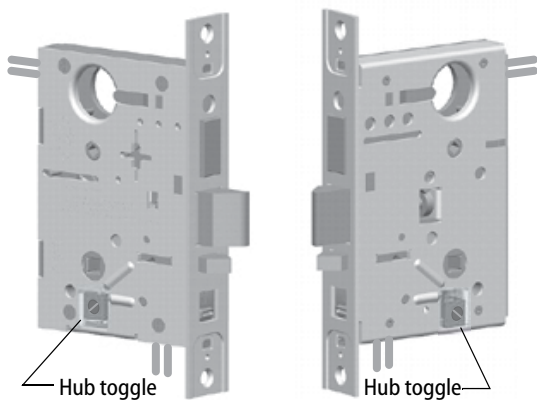

Figure 9 Positioning hub toggles

9 Position hub toggles (if necessary)

- 1 Check whether the hub toggles are in the proper position for the lock. See the table below and Figure 9.

Hub toggle positions

Function	Hub toggle positions
DEU/DEL, LEU/LEL, NXEU/NXEL, TDEU/TDEL	Inside down (always unlocked) & outside up (lockable)

Note 1: For LH & LHRB doors, the inside is the back side of the case and the outside is the cover side of the case. For RH & RHRB doors, the inside is the cover side of the case and the outside is the back side of the case. The cover is mounted to the case with four screws.

Note 2: If the lock has an optional RQE status sensor, two RQE status switches are installed in the mortise case. However, only the switch for the inside of the lock needs to be connected. Before you install the mortise case in the door, determine whether you need to connect the 'Case Side' pair of RQE wires or the 'Cover Side' pair of RQE wires, based on the handing of the door.

- 2 To change the position of a hub toggle, remove the toggle screw, move the toggle into the desired position, and re-tighten the screw.

10 Install mortise case

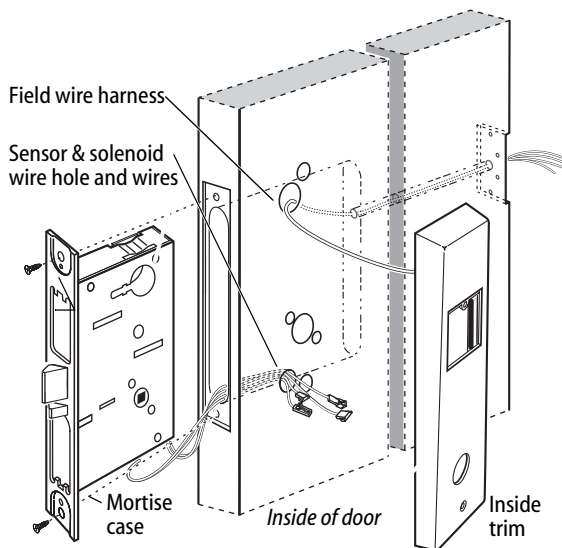

Figure 10 Installing the mortise case (inside of door)

- 1 Remove the faceplate from the mortise case, if necessary.
- 2 Insert the mortise case into the mortise cavity, while feeding the sensor and solenoid wires into the mortise cavity and out the sensor & solenoid wire hole to the inside of the door.

Note 1: The armored front of the mortise case self-adjusts to the door bevel.

Note 2: The field wire harness should be routed above and behind the mortise case (depending on where the hole through the door meets the mortise cavity).

- 3 Make sure there are 3" to 4" of slack in the field wire harness to allow access to the control electronics circuit board in the inside trim.
- 3 Secure the mortise case with the case mounting screws.

Installing the trim

11 Install wire transfer hinge

Note: BEST recommends one of the following concealed electric hinges from Stanley Security Solutions. For more information, contact your BEST representative.

Hinge	Description†
CECB 179-66	Standard weight; steel
CECB 168-66	Heavy weight; steel
CECB 191-66	Standard weight; brass

† All hinges measure 4.5" × 4.5" and have a 26D finish. All hinges have two 24 AWG wires rated for 2 A at 12 or 24 volts (AC or DC) and four 28 AWG wires rated for 1 A at 12 or 24 volts (AC or DC).

- 1 Trim the power and sensor wires that you pulled through the hinge edge of the door. Leave sufficient length to connect to the wire transfer hinge and to allow for future splices.
 - 2 Splice the field wires to the leads on the frame side of the hinge, following the hinge manufacturer's instructions.
 - 3 Splice the power and sensor wires from the lock to the leads on the door side of the hinge, matching each lead to its corresponding wire.
- Note:** If the lock has an optional RQE status sensor, splice only the pair of RQE wires for the switch on the inside of the door, which you identified in Task 9 on page 6. Put the unused pair of RQE wires in the door.
- 4 Insert the wires and splice connectors into the holes or pockets in the door and frame, being careful not to pinch the wires. Install the wire transfer hinge.

12 Install trim mounting plates

- 1 Insert the outside trim mounting plate through the door and mortise case.
- 2 Position the inside trim mounting plate opposite the outside trim mounting plate and screw them securely in place.

Caution: Do not overtighten the trim mounting plate screws. Overtightening may damage the locking mechanism.

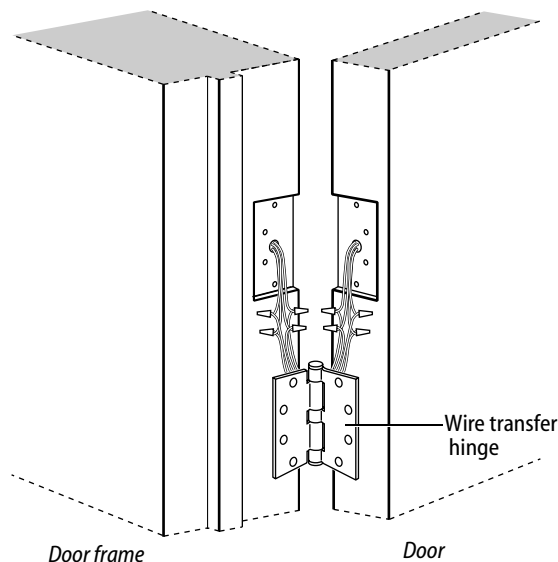

Figure 11 Installing the wire transfer hinge

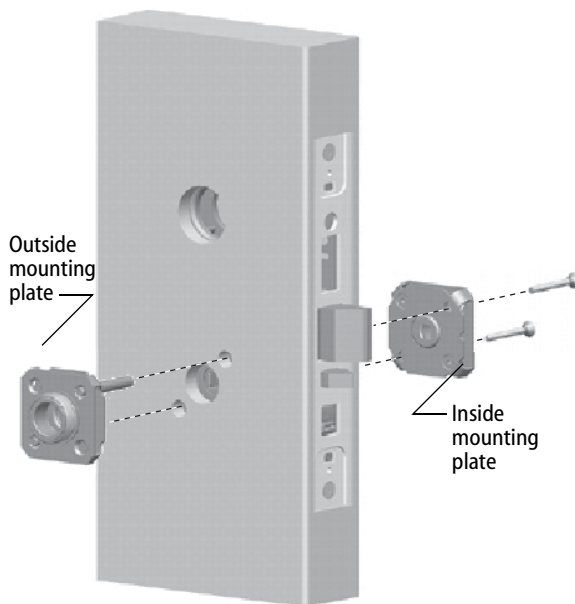

Figure 12 Installing the trim mounting plates

Installing the trim

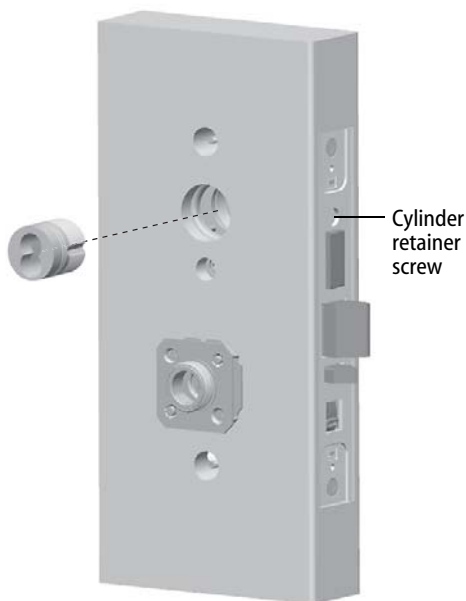

Figure 13 Installing the concealed cylinder

13 Install concealed cylinder & core (DEU/DEL and TDEU/TDEL functions only)

- 1 Use a cylinder wrench to thread the cylinder into the mortise case so that the groove around the cylinder is even with the door surface as shown in Figure 13.

Caution: A malfunction can occur if the cylinder is threaded in too far.

- 2 Secure the cylinder in the mortise case with the cylinder retainer screw.
- 3 Insert the control key into the core and rotate the key 15 degrees to the right.
- 4 With the control key in the core, insert the core into the cylinder.
- 5 Rotate the control key 15 degrees to the left and withdraw the key.

- 6 **The control key can be used to remove cores and to access doors. Provide adequate security for the control key.**

Installing the trim

14 Install trim hole inserts and bushings

- 1 Insert the two trim hole inserts into the upper trim hole on each side of the door, as shown in Figure 14.
- 2 Insert two bushings into the field harness & reader wire hole on each side of the door, as shown in Figure 14.
- 3 Insert a bushing into the sensor & solenoid wire hole on the inside of the door, as shown in Figure 14.

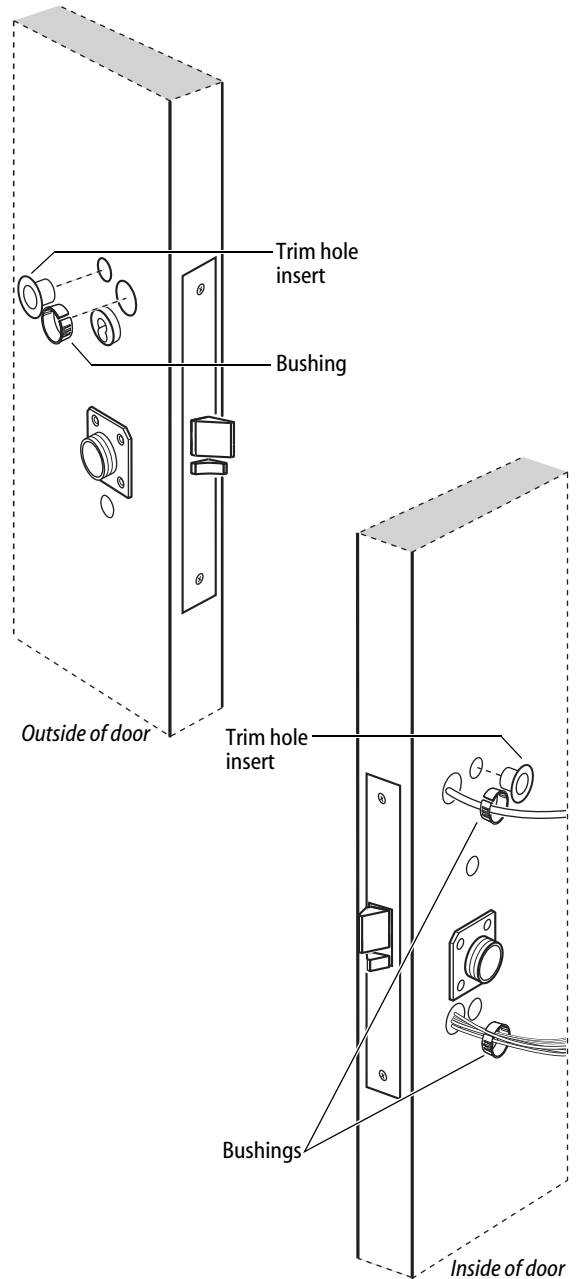

Figure 14 Installing the trim hole inserts and bushings

Installing the trim

15 Connect reader wire harness

- 1 From the outside of the door, feed the reader wire harness connector through the field harness & reader wire hole.
- 2 Temporarily rest the outside trim on the door by inserting the trim studs into the stud holes.
Note: You can temporarily install the outside knob/lever to hold the outside trim in place. See Task 17.
- 3 Connect the reader wire harness to the control electronics circuit board in the inside trim.
- 4 Feed the solenoid and sensor wire harness from the control electronics circuit board, as well as the solenoid and sensor wires from the mortise case, through the large opening in the inside trim.

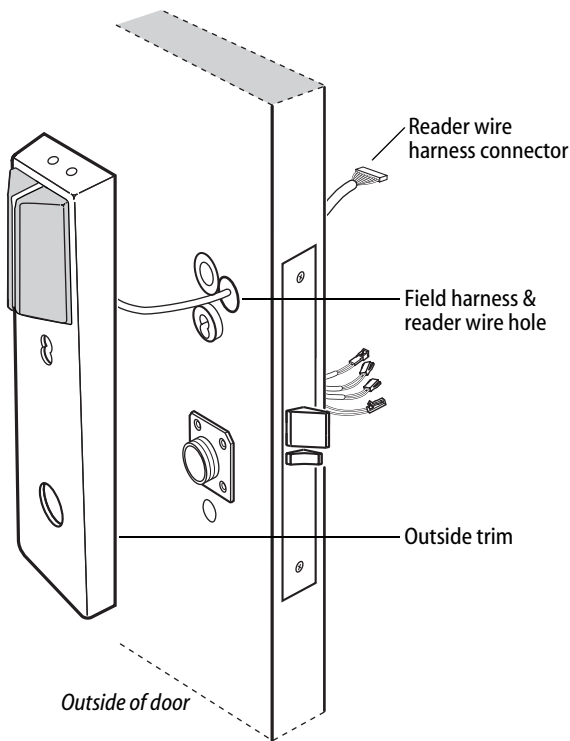

Figure 15a Feeding the reader wire harness connector from the outside trim through the door

Caution 1: When routing the reader wire harness, make sure the reader wire harness is not routed across any sharp edges or over any surface that could damage its sleeving or wire insulation.

Caution 2: When connecting the reader wire harness, make sure:

- there are no loose wire connections where the wires are inserted into the reader wire connector
- the reader wire harness connector is fully seated in its mating connector on the control electronics circuit board.

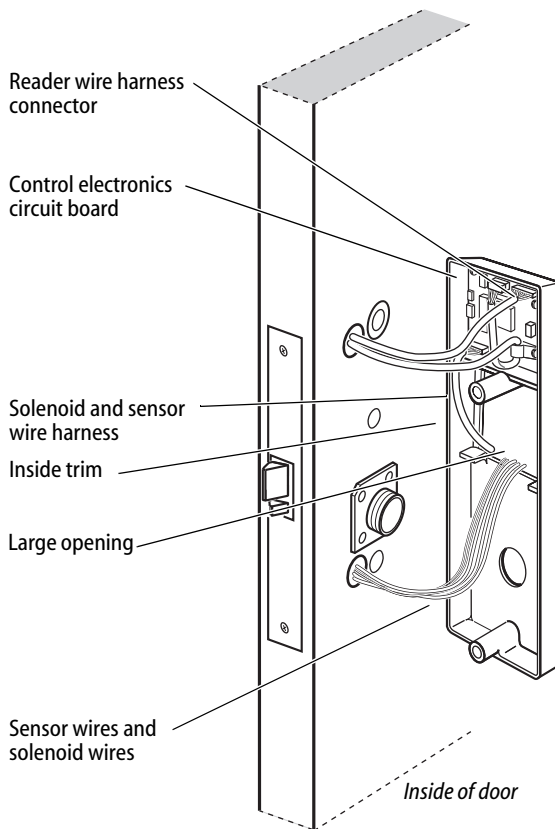

Figure 15b Connecting the reader wire harness to the control electronics circuit board

Installing the trim

16 Set the control electronics board DIP switches

Each IDH Max unit must be addressable (able to be identified automatically by the access control system) with a unique address that matches its Lenel or B.A.S.I.S.® reader address set up in the management software. See the *System Administration User Guide* for more information on reader addressing.

- 1 On the inside control electronics board use the first five switches to set the reader address in binary code. Switch one is the least significant digit. See the table on the next page.
- 2 Use the table below to set both switches 6 and 7 to the baud rate at which the locks will communicate with the intelligent controller.

Baud rate	Switch 6	Switch 7
2,400	All off	
9,600		ON
19,200	ON	
38,400	ON	ON

- 3 For the last IDH Max Lock in the daisy-chain only, set switch 8 to ON. Otherwise, set switch 8 to OFF.

Installing the trim

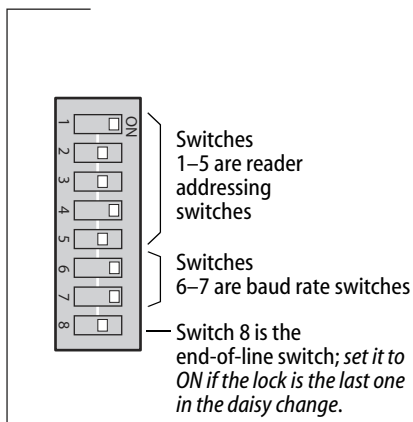

Figure 16 DIP switches on the Control Electronics circuit board set to reader address 5 and 38,400 bps baud rate and not end of line.

For example, to address an IDH Max Lock with address number 5, the binary equivalent number would be 00101 – OFF OFF ON OFF ON. See table below.

Reader address	(16) Switch 5	(8) Switch 4	(4) Switch 3	(2) Switch 2	(1) Switch 1
0			All off		
1					ON
2				ON	
3				ON	ON
4			ON		
5			ON		ON
6			ON	ON	
7			ON	ON	ON
8		ON			
9		ON			ON
10		ON		ON	
11		ON		ON	ON
12		ON	ON		
13		ON	ON		ON
14		ON	ON	ON	
15		ON	ON	ON	ON
16	ON				
17	ON				ON
18	ON			ON	
19	ON			ON	ON
20	ON		ON		
21	ON		ON		ON
22	ON		ON	ON	
23	ON		ON	ON	ON
24	ON	ON			
25	ON	ON			ON
26	ON	ON		ON	
27	ON	ON		ON	ON
28	ON	ON	ON		
29	ON	ON	ON		ON
30	ON	ON	ON	ON	
31	ON	ON	ON	ON	ON

Completing the installation at the door

17 Secure through-bolt trim and complete connections

- 1 Position the inside and outside trim onto the door.
- 2 **Making sure that the trim does not pinch the wires**, secure the trim to the door—but do not tighten. Use the combination mounting screw at the top trim hole and the standard mounting screw at the bottom trim hole.

Caution: When routing the solenoid and sensor wire harness, the sensor wires, and the solenoid wires, make sure the wires are not routed across any sharp edges or over any surface that could damage their sleeving or wire insulation.

- 3 Make the solenoid connection and three sensor connections, and place the wires into the inside trim.

Wire connection	Color	No. of wires	No. of pins
Solenoid	Yellow	2	3
RQE	Brn/Org	2	3
Shorting connection	Purple	2	2
Door status sensor	White	2	2

Caution: When making the sensor connections and solenoid connection, make sure:

- there are no loose wire connections where the wires are inserted into the connectors
- the connectors are firmly mated.

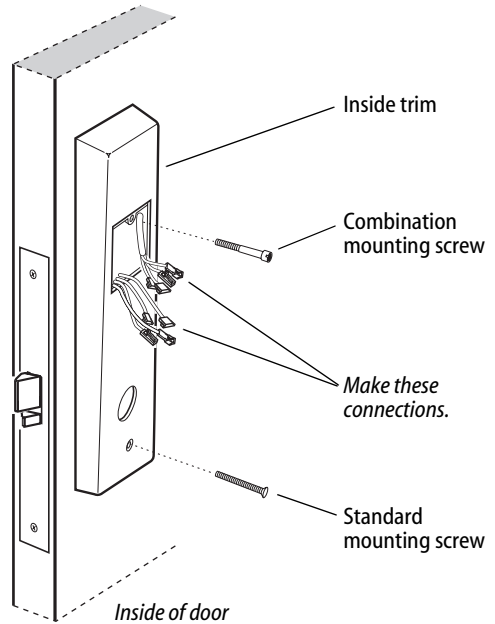

Figure 17 Securing the through-bolt trim and completing connections

Completing the installation at the door

18 Install inside and outside knobs/levers

For both knobs and levers

Unscrew the inside spindle one full turn to allow the spindles to turn freely.

For knobs

- 1 From the outside of the door, insert the outside knob and spindles assembly into the lockset.
- 2 Slide the inside knob onto the inside spindle and secure it with the set screw.
- 3 Push the set screw cap into the set screw hole.
- 4 Tighten the trim mounting screws.
- 5 Turn the knobs to check that they operate smoothly.

For levers

- 1 With the handle pointing toward the door hinges, insert the outside lever and spindles assembly into the lock from the outside of the door.
- 2 Slide the inside lever onto the inside spindle and secure it with the set screw.
- 3 Tighten the trim mounting screws.
- 4 Turn the levers to check that they operate smoothly.

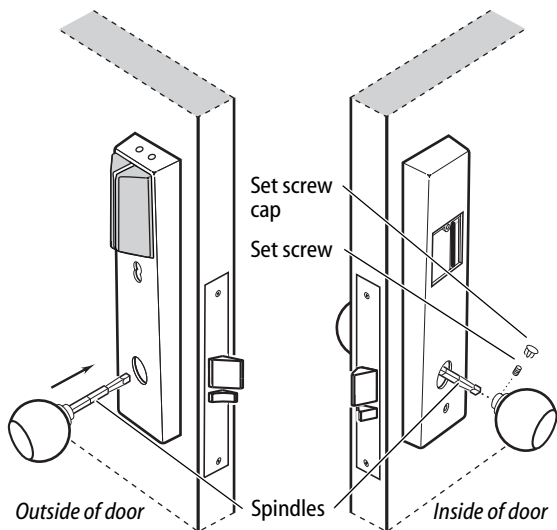

Figure 18a Installing the knobs

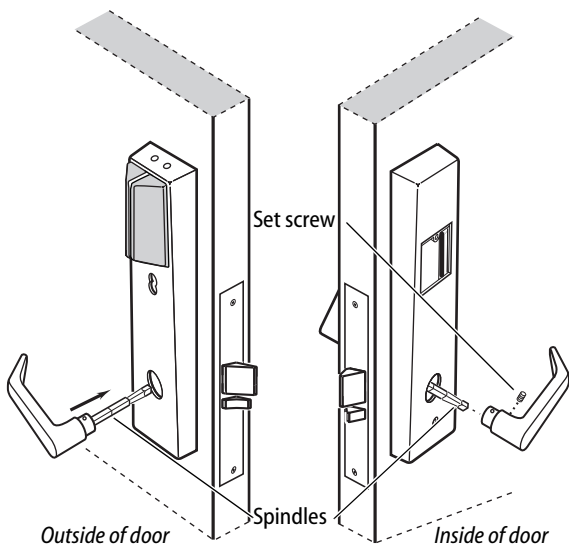

Figure 18b Installing the levers

Completing the installation at the door

19 Install core (DEU/DEL and TDEU/TDEL only)

- 1 Insert the control key into the core and rotate the key 15 degrees to the right.
- 2 With the control key in the core, insert the core into the cylinder.
- 3 Rotate the control key 15 degrees to the left and withdraw the key.

Caution: The control key can be used to remove cores and to access doors. Provide adequate security for the control key.

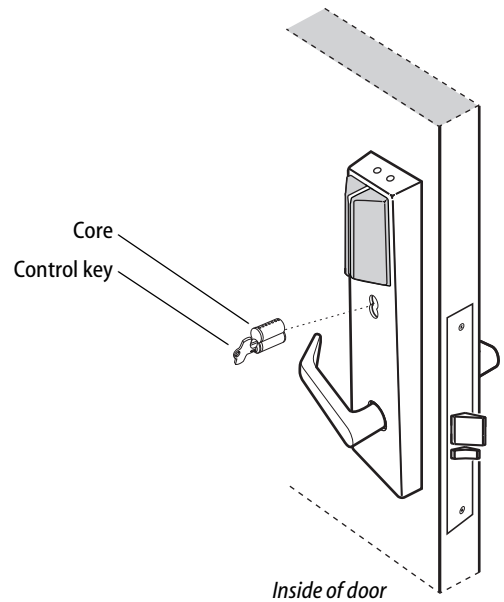

Figure 19 Installing the core

20 Install access door

- 1 **Making sure that the access door does not pinch any wires**, insert the tabs of the access door into its mating slots and swing the door closed.
- 2 Use a T15 TORX bit driver to secure the access door with the security screw. Tighten firmly.

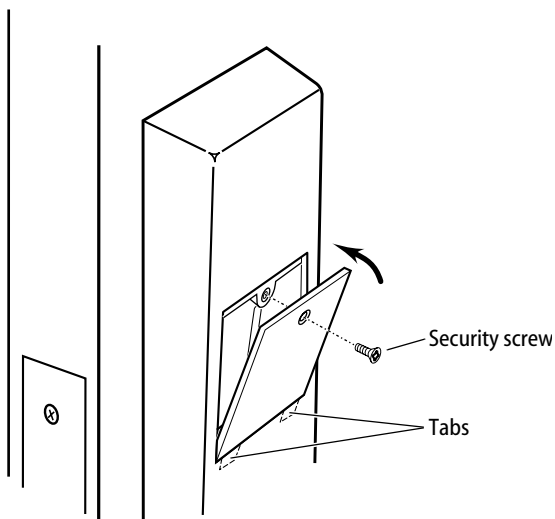

Figure 20 Installing the access door

Completing the installation at the door

21 Install strike box and strike plate

- 1 Insert the strike box into the mortise in the door jamb. Place the strike plate over the strike box and secure the strike with the screws provided.
- 2 Check the position of the auxiliary bolt against the strike plate.

Caution: The auxiliary bolt must make contact with the strike plate. The auxiliary bolt deadlocks the latchbolt and prevents someone from forcing the latch open when the door is closed. If the incorrect strike is installed, a lock-in can occur.

Note: The recommended gap between the door and jamb is 1/8".

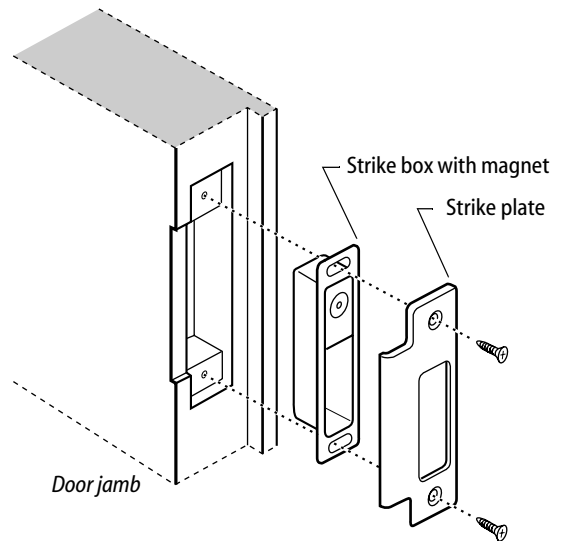

Figure 21a Installing the strike box and strike plate

22 Optional: Install lock power supply

If you are providing a separate power supply for the lock, instead of providing power via the panel interface module, connect the two power field wires (run from the wire transfer hinge) to the power supply. Make sure power (12 volts DC) and ground are connected properly.

Follow the instructions provided by the power supply manufacturer. Do not plug in the power supply yet.

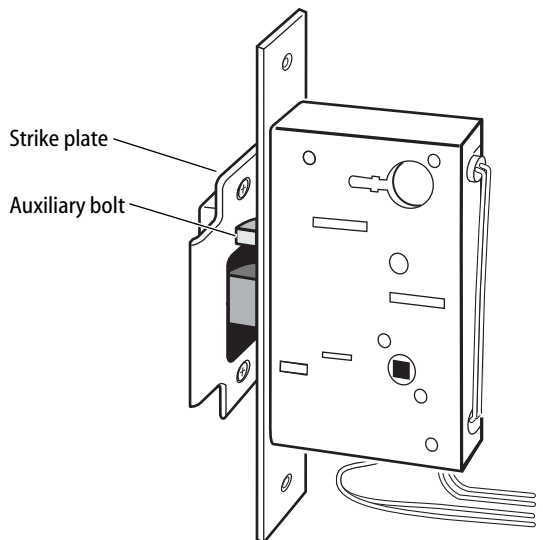

Figure 21b Positioning the strike

Testing the installation

23 Connect to the BAS-500 or BAS-1000 access control panel

- 1 If necessary daisy-chain all IDH Max Locks by splicing like wires and make all necessary wire runs to either a BAS-500 or BAS-1000 panel.

Note: A BAS-500 panel will accept up to 16 IDH Max 1300 locks and a BAS-1000 panel will accept up to 32 IDH Max 1300 locks.

- 2 Connect the orange wire or its extension to the RS485 connection TR2+ or higher. See Figure 23.
- 3 Connect the green wire or its extension to the RS485 connection TR2- or higher.
- 4 Connect the shield strand to the RS485 connection GND (ground).

24 Test the installation

After downloading the panel information to the IDH Max Locks, perform the following steps to test the installation. Also, perform any standard testing recommended by the manufacturer of the access control panel. If you encounter problems, see *Troubleshooting the installation*, on page 19.

- 1 Check the control electronics' red status LED.
Both LEDs should be blinking red, indicating that the communication connection between the access control panel and the lock's control electronics circuit board is OK.
- 2 After performing any necessary programming for the lock and putting the door in a locked mode, use a valid token to access the lock.
Confirm that the red reader LED, green reader LED, and sounder respond as expected.
The lock should allow access, verifying that the solenoid is working.
To check that the reader is working, view the lock's event history and verify that the information recorded for the token is correct.
- 3 Use an invalid token to attempt to access the lock.
Confirm that the red reader LED, green reader LED, and sounder respond as expected.
The lock should deny access.
- 4 With the door armed, attempt to exit through the door.
The request-to-exit (RQE) feature should let you exit without triggering an alarm by the access control panel.
- 5 Remove power from the lock and check whether the door remains locked or is unlocked.
Verify that the lock fails safe or secure, according to its function.
- 6 With the door armed, hold the door open. Hold a magnet against the edge of the door, over the door status

Troubleshooting the installation

sensor, until the access control panel sees the door as closed. Then remove the magnet.

Verify that the appropriate alarm response is triggered by the access control panel, indicating that the door status sensor is working.

- 7 With the door armed, hold the door open. Hold a magnet against the edge of the door, over the door status sensor, until the access control panel sees the door as closed. With the magnet in place, push in the latch-bolt.

Verify that the appropriate alarm response is triggered by the access control panel, indicating that the latch-bolt status sensor is working.

Troubleshooting

To troubleshoot installation problems, refer to the table below. For more information, refer to the *IDH Max Lock Service Manual (T60775)* and to the documentation provided by the manufacturer of the access control panel/reader interface.

You notice . . .	Possible causes include . . .	You should . . .
Control electronics' red status LED and access control panel's red status LED are on only 20% of the time.	Communication between the lock's control electronics circuit board and the access control panel has been interrupted.	<p>Make sure DIP switches 6 and 7 on the lock's control electronics circuit board are set to the proper baud rate. See page 11.</p> <p>Check the connections for all communication field wiring.</p> <p>Make sure that the last daisy-chained IDH Max DIP switch is set to ON and all others are OFF. See page 11.</p> <p>Check the communication connections between the field wire harness and the wire transfer hinge.</p>
Control electronics' red status LED is off.	Power is not being supplied to the lock.	<p>Make sure that the lock's power supply is connected to electrical service.</p> <p>Check the connections for all power field wiring to the lock.</p> <p>Check the power connections between the field wire harness and the wire transfer hinge.</p>

